



EirGrid Grid Code

Version 3.3

Modifications approved January 30th 2009

This version comes into effect January 30<sup>th</sup> 2009

(Wind Grid Code only)

**WFPS1 CONTROLLABLE WIND FARM POWER STATION GRID CODE  
PROVISIONS**

**WFPS1.1 INTRODUCTION .....WFPS1-3**  
**WFPS1.2 OBJECTIVE .....WFPS1-3**  
**WFPS1.3 SCOPE .....WFPS1-3**  
**WFPS1.4 FAULT RIDE THROUGH REQUIREMENTS .....WFPS1-1**  
**WFPS1.5 TRANSMISSION SYSTEM FREQUENCY REQUIREMENTS .....WFPS1-6**  
**WFPS1.6 TRANSMISSION SYSTEM VOLTAGE REQUIREMENTS.....WFPS1-14**  
**WFPS1.7 SIGNALS, COMMUNICATIONS & CONTROL.....WFPS1-19**

## **WFPS 1      CONTROLLABLE WIND FARM POWER STATION GRID CODE PROVISIONS**

### **WFPS1.1      INTRODUCTION**

All **Generators** connecting to the **Transmission System** are required to comply with the **Grid Code**. The **Grid Code** was originally developed with synchronous generators in mind. Since **Wind Turbine Generators (WTG)** do not have the same characteristics as synchronous generators, it was considered appropriate to develop a new set of **Grid Code** provisions specifically for **Controllable WFPSs**. This section of the **Grid Code** gives the specific requirements for **Controllable WFPSs**.

### **WFPS1.2      OBJECTIVE**

The primary objective of WFPS1 is to establish the technical rules which **Controllable WFPSs** must comply with in relation to their connection to and operation on the **Transmission System**.

### **WFPS1.3      SCOPE**

WFPS1.3.1      WFPS1 applies to the following **Users**:

- (a) The **TSO**; and
- (b) **Grid Connected Controllable WFPSs**.

WFPS1.3.2      In addition to WFPS1, **Controllable WFPSs** are required to comply with the following sections of the **Grid Code**:

- GC - General Conditions
- PC - Planning Code
- PCA – Planning Code Appendix
- CC- Connection Conditions excluding:
  - *CC 7.2.5.1*
  - *CC 7.2.5.2*
  - *CC7.3.1.1(a) to (h) and (j) to (u)*
  - *CC7.3.1.2*
  - *CC7.3.5*
  - *CC7.3.6*
  - *CC7.3.7*
  - *CC7.3.8*

- CC.12.2
- CC.12.3
- OC1
- OC2
- OC4 excluding:
  - OC4.3.4
  - OC4.4.5.3
  - OC4.4.5.4
  - OC4.4.5.5
- OC6
- OC7 excluding
  - OC7.2.4.2
- OC8
- OC9
- OC10 excluding
  - OC10.5.7
  - OC10.7.1
  - OC10.7.2
  - OC10.7.3
  - OC10.7.4
  - OC10.7.6
- OC11
- SDC1

**Dispatchable WFPSs** are also required to comply with SDC2.

In the **Grid Code**, where applicable, for the purposes of **Controllable WFPSs** references to **Generation Unit** or **Generator** should be interpreted to mean **Controllable WFPS**.

#### WFPS1.4 FAULT RIDE THROUGH REQUIREMENTS

WFPS1.4.1 A **Controllable WFPS** shall remain connected to the **Transmission System** for **Transmission System Voltage** dips on any or all phases, where the **Transmission System Phase Voltage** measured at the HV terminals of the **Grid Connected Transformer** remains above the heavy black line in *Figure WFPS1.1*.

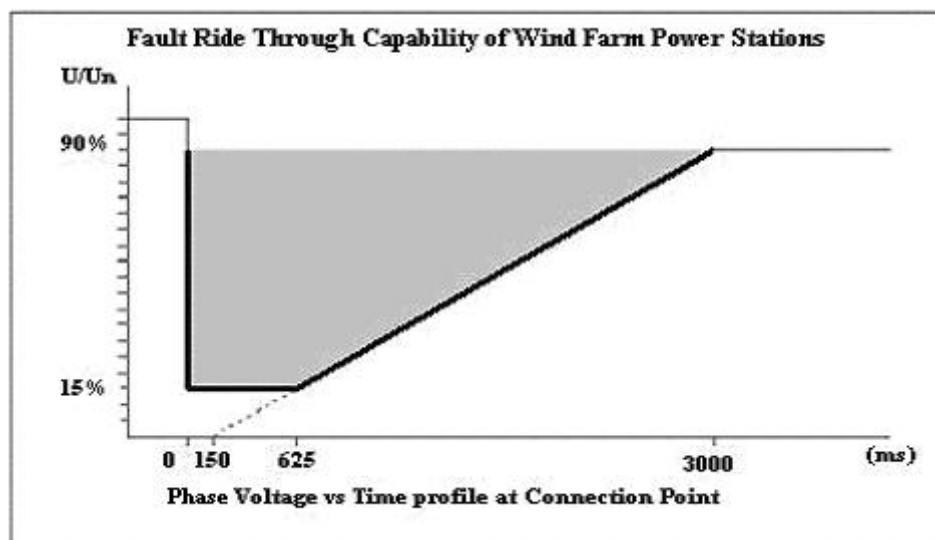

Figure WFPS1.1 - Fault Ride-Through Capability of **Controllable WFPSs**

WFPS1.4.2 In addition to remaining connected to the **Transmission System**, the **Controllable WFPS** shall have the technical capability to provide the following functions:

- a) During the **Transmission System Voltage** dip the **Controllable WFPS** shall provide **Active Power** in proportion to retained **Voltage** and maximise reactive current to the **Transmission System** without exceeding **WTG** limits. The maximisation of reactive current shall continue for at least 600 ms or until the **Transmission System Voltage** recovers to within the normal operational range of the **Transmission System** (ref. WFPS1.6.1), whichever is the sooner;
- b) The **Controllable WFPS** shall provide at least 90 % of its maximum **Available Active Power** as quickly as the technology allows and in any event within 1 second of the **Transmission System Voltage** recovering to the normal operating range (ref. WFPS1.6.1).

## **WFPS1.5.1 TRANSMISSION SYSTEM FREQUENCY RANGES**

**Controllable WFPSs** shall have the capability to:

- a) operate continuously at normal rated output at **Transmission System Frequencies** in the range 49.5 Hz to 50.5 Hz;
- b) remain connected to the **Transmission System** at **Transmission System Frequencies** within the range 47.5 Hz to 52.0 Hz for a duration of 60 minutes;
- c) remain connected to the **Transmission System** at **Transmission System Frequencies** within the range 47.0 Hz to 47.5 Hz for a duration of 20 seconds required each time the **Transmission System Frequency** is below 47.5 Hz;
- d) remain connected to the **Transmission System** during rate of change of **Transmission System Frequency** of values up to and including 0.5 Hz per second.

No additional **WTG** shall be started while the **Transmission System Frequency** is above 50.2 Hz.

## **WFPS1.5.2 ACTIVE POWER MANAGEMENT**

A **Wind Farm Control System** shall be installed by the **Controllable WFPS** to allow for the provision of **Active Power Control** and **Frequency Response** from the **Controllable WFPS**. The **Wind Farm Control System** and **Frequency Response System** shall provide the functionality as specified in this section WFPS1.5.2.

### **WFPS1.5.2.1 Active Power Control**

The **Wind Farm Control System** shall be capable of operating each **WTG** at a reduced level if the **Controllable WFPS's Active Power** output has been restricted by the **TSO**. The **Wind Farm Control System** shall be capable of receiving an on-line **Active Power Control Set-point** sent by the **TSO** and shall commence implementation of the set-point within 10 seconds of receipt of the signal from the **TSO**. The rate of change of output to achieve the **Active Power Control Set-point** should be no less than the maximum

ramp rate settings of the **Wind Farm Control System**, as advised by the TSO, as per WFPS1.5.3.

### WFPS1.5.2.2 Frequency Response

WFPS1.5.2.2.1 The **Frequency Response System** shall have the capabilities as displayed in the *Power-Frequency Response Curve* in *Figure WFPS1.2*, where the power and frequency ranges required for points A, B, C, D, E are defined below in *Table WFPS1.1* and *Table WFPS1.2*.

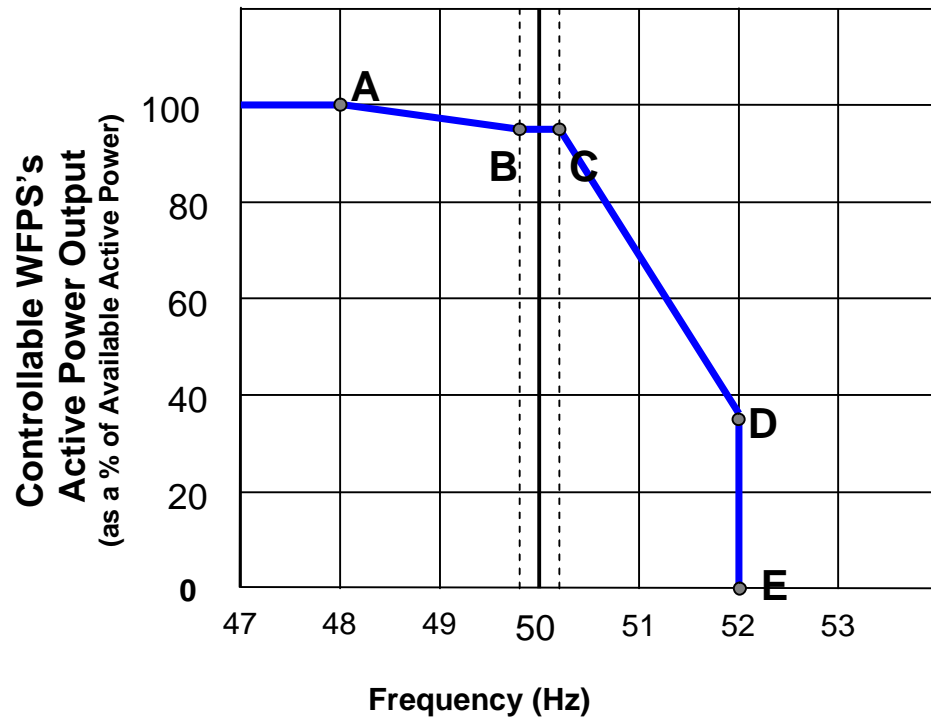

*Figure WFPS1.2 – Example of Power-Frequency Response Curve.*

WFPS1.5.2.2.2 Under normal **Transmission System Frequency** ranges, the **Controllable WFPS** shall operate with an **Active Power** output as set by the line 'B' - 'C'. If the **Transmission System Frequency** falls below point 'B', then the **Frequency Response System** shall act to ramp up the **Controllable WFPS's Active Power** output, in accordance with the **Frequency/Active Power** characteristic defined by the line 'B'-'A'.

WFPS1.5.2.2.3 Where the **Transmission System Frequency** is below the normal range and is recovering back towards the normal range, the **Frequency Response System** shall act to ramp down the **Controllable WFPS's Active Power** output in accordance with the **Frequency/Active Power** characteristic defined by the line 'A'-'B'.

WFPS1.5.2.2.4 A **Frequency** dead-band shall be applied between the **Transmission System Frequencies** corresponding to points 'B' and 'C', where no change in the **Controllable WFPS's Active Power** output shall be required.

WFPS1.5.2.2.5 Once the **Transmission System Frequency** rises to a level above point 'C', the **Frequency Response System** shall act to ramp down the **Controllable WFPS's Active Power** output in accordance with the **Frequency/Active Power** characteristic defined by the line 'C'-'D'-'E'. At **Transmission System Frequencies** greater than or equal to 'D'-'E', there shall be no **Active Power** output from the **Controllable WFPS**.

WFPS1.5.2.2.6 Points 'A', 'B', 'C', 'D' and 'E' shall depend on a combination of the **Transmission System Frequency, Active Power** and **Active Power Control Set-point** settings. These settings may be different for each **Controllable WFPS** depending on system conditions and **Controllable WFPS** location. These settings are defined in *Table WFPS1.1* below.

Point	<b>Transmission System Frequency (Hz)</b>	<b>Controllable WFPS Active Power Output (% of Available Active Power)</b>
A	$F_A$	$P_A$
B	$F_B$	Minimum of : $P_B$ or <b>Active Power Control Set-point</b> (converted to a % of <b>Available Active Power</b> )
C	$F_C$	Minimum of: $P_C$ or <b>Active Power Control Set-point</b> (converted to a % of <b>Available Active Power</b> )
D	$F_D$	Minimum of: $P_D$ or <b>Active Power Control Set-point</b> (converted to a % of <b>Available Active Power</b> )
E	$F_E$	$P_E = 0 \%$

*Table WFPS1.1: Transmission System Frequency and % Available Active Power Settings for the Points 'A', 'B', 'C', 'D' and 'E' illustrated in Figure WFPS1.2*

Two settings for each of  $F_A, F_B, F_C, F_D, F_E, P_A, P_B, P_C, P_D$  and  $P_E$  shall be specified by the **TSO** at least **120 Business Days** prior to the **Controllable WFPS's** scheduled **Operational Date** (refer to 1.5.2.3 below). The

**Controllable WFPS** shall be responsible for implementing the appropriate settings during **Commissioning**.

Alterations to the **Active Power Control Set-point** may be requested in real-time by the **TSO** and the implementation of the set-point shall commence within 10 seconds of receipt of the signal from the **TSO**. The rate of change of output to achieve the **Active Power Control Set-point** should be no less than the maximum ramp rate settings of the **Wind Farm Control System**, as advised by the **TSO**, as per WFPS1.5.3.

WFPS1.5.2.2.7 The table below, *Table WFPS1.2*, shows the **Transmission System Frequency** and **Active Power** ranges for  $F_A$ ,  $F_B$ ,  $F_C$ ,  $F_D$ ,  $F_E$ ,  $P_A$ ,  $P_B$ ,  $P_C$ ,  $P_D$  and  $P_E$ .

	<b>Transmission System Frequency (Hz)</b>		<b>Available Active Power (%)</b>	
			<b>MEC &gt; 10 MW</b>	<b>5 MW &lt; MEC ≤ 10 MW</b>
$F_A$	47.0-51.0	$P_A$	50-100	100
$F_B$	49.5-51.0	$P_B$	50-100	100
$F_C$	49.5-51.0	$P_C$		
$F_D$	50.5-52.0	$P_D$	20-100	20-100
$F_E$		$P_E$	0	0

*Table WFPS1.2: Transmission System Frequency & Active Power ranges appropriate to Figure WFPS1.2.*

For the **Transmission System Frequency** values in *Table WFPS1.2* above,  $F_A \leq F_B \leq F_C \leq F_D = F_E$ .

WFPS1.5.2.2.8 Alterations to the **Controllable WFPS's Active Power** output, triggered by **Transmission System Frequency** changes, shall be achieved by proportionately altering the **Active Power** output of all available **WTGs** as opposed to switching individual **WTGs** on or off, insofar as possible.

WFPS1.5.2.2.9 No time delay other than those necessarily inherent in the design of the **Frequency Response System** shall be introduced. The response rate of each available online **WTG** shall be a minimum of 1 % of **WTG** rated capacity per second (MW/second). The **Frequency Response System** shall continuously monitor the **Transmission System Frequency** in order to continuously determine the **Controllable WFPS's** appropriate **Active Power**

output by taking account of the **Controllable WFPS's Available Active Power** or **Controlled Active Power**.

WFPS1.5.2.2.10 If the **Transmission System Frequency** rises to a level above 'D'-'E', as defined by the *Power-Frequency Response Curve in Figure WFPS1.2*, the **TSO** accepts that **WTGs** may disconnect. Any **WTG** which has disconnected shall be brought back on load as fast as technically feasible (provided the **Transmission System Frequency** has fallen below 50.2 Hz).

### **WFPS1.5.2.3 Procedure for Setting and Changing the *Power-Frequency Response Curves***

Two *Power-Frequency Response Curves* (Curve 1 and Curve 2) shall be specified by the **TSO** at least 120 **Business Days** prior to the **Controllable WFPS's** scheduled **Operational Date**. The **Controllable WFPS** shall be responsible for implementing the appropriate settings during **Commissioning**. The **Frequency Response System** shall be required to change between the two curves within one minute from receipt of the appropriate signal from the **TSO**. The **TSO** shall give the **Controllable WFPS** a minimum of 2 weeks notice if changes to either of the curve's parameters (*i.e.  $F_A, F_B, F_C, F_D, F_E, P_A, P_B, P_C, P_D$  or  $P_E$* ), are required. The **Controllable WFPS** shall formally confirm that any requested changes have been implemented within two weeks of receiving the **TSO's** formal request.

### **WFPS1.5.3 RAMP RATES**

**WFPS1.5.3.1** The **Wind Farm Control System** shall be capable of controlling the ramp rate of its **Active Power** output with a maximum MW per minute ramp rate set by the **TSO**. There shall be two maximum ramp rate settings. The first ramp rate setting shall apply to the MW ramp rate average over one (1) minute. The second ramp rate setting shall apply to the MW per minute ramp rate average over ten (10) minutes. These ramp rate settings shall be applicable for all ranges of operation including start up, normal operation and shut down. The **TSO** acknowledges that falling wind speed or **Frequency Response** may cause either of the maximum ramp rate settings to be exceeded.

**WFPS1.5.3.2** It shall be possible to vary each of these two maximum ramp rate settings independently over a range between 1 and 30 MW per minute. The **Wind Farm Control System** shall have the capability to set the ramp rate in MW per minute averaged over both one and ten minutes.

### **WFPS1.5.3.3 Procedure for Setting and Changing the Ramp Rate Control**

The ramp rate settings shall be specified by the **TSO** at least 120 **Business Days** prior to the **Controllable WFPS's** scheduled **Operational Date**. The **Controllable WFPS** shall be responsible for implementing the appropriate settings during **Commissioning**. The ramp rate settings may need to be changed from time to time depending on system needs. The **TSO** shall give

the **Controllable WFPS** a minimum of two weeks notice if a change is required. The **Controllable WFPS** shall formally confirm that any requested changes have been implemented within two weeks of receiving the **TSO's** formal request.

## **WFPS1.6 TRANSMISSION SYSTEM VOLTAGE REQUIREMENTS**

### **WFPS1.6.1 TRANSMISSION SYSTEM VOLTAGE RANGE**

**Controllable WFPSs** shall remain continuously connected to the **Transmission System** at maximum **Available Active Power** or **Controlled Active Power** output for normal and disturbed system conditions and for step changes in **Transmission System Voltage** of up to 10 %. The following are the ranges which may arise during **Transmission System** disturbances or following transmission faults:

- (a) 400 kV system: 350 kV to 420 kV;
- (b) 220 kV system: 200 kV to 245 kV;
- (c) 110 kV system: 99 kV to 123 kV.

### **WFPS1.6.2 AUTOMATIC VOLTAGE REGULATION**

WFPS1.6.2.1 **Controllable WFPSs** shall have a continuously-variable and continuously-acting **Voltage Regulation System** with similar response characteristics to a conventional **Automatic Voltage Regulator** and shall perform generally as described in BS4999 part 140, or equivalent European Standards.

WFPS1.6.2.2 The **Voltage Regulation System** shall be capable of receiving a **Voltage Regulation Set-point** for the **Voltage** at the **Connection Point**. The **Voltage Regulation System** shall act to regulate the **Voltage** at this point by continuous modulation of the **Controllable WFPS's Reactive Power** output, within its **Reactive Power** range and without violating the **Voltage Step Emissions** limits as set out in the IEC standard 61000-3-7:1996 *Assessment of Emission limits for fluctuating loads in MV and HV power systems*. A change to the **Voltage Regulation Set-point** shall be implemented by the **Controllable WFPS** within 20 seconds of receipt of the appropriate signal from the **TSO**.

WFPS1.6.2.3 The **Voltage Regulation System Slope Setting** shall be capable of being set to any value between 1 % and 10 %. The setting shall be specified by the **TSO** at least 120 **Business Days** prior to the **Controllable WFPS's** scheduled **Operational Date**. The **Controllable WFPS** shall be responsible for implementing the appropriate settings during **Commissioning**. The slope setting may be varied from time to time depending on **Transmission System** needs. The **TSO** shall give the **Controllable WFPS** a minimum of two weeks

notice if a change is required. The **Controllable WFPS** shall formally confirm that any requested changes have been implemented within two weeks of receiving the **TSO's** formal request.

WFPS1.6.2.4 The speed of response of the **Voltage Regulation System** shall be such that, following a step change in **Voltage** at the **Connection Point** the **Controllable WFPS** shall achieve 90 % of its steady-state **Reactive Power** response within 1 second. The response may require a transition from maximum **Mvar** production to maximum **Mvar** absorption or vice-versa.

WFPS1.6.2.5 *Figure WFPS1.3* shows the relevant points appropriate to the **Voltage Regulation System** for a **Controllable WFPS**. X is the HV side of the **WTG** transformer, Y is the lower voltage side of the **Grid Connected Transformer** and Z is the **Connection Point**.

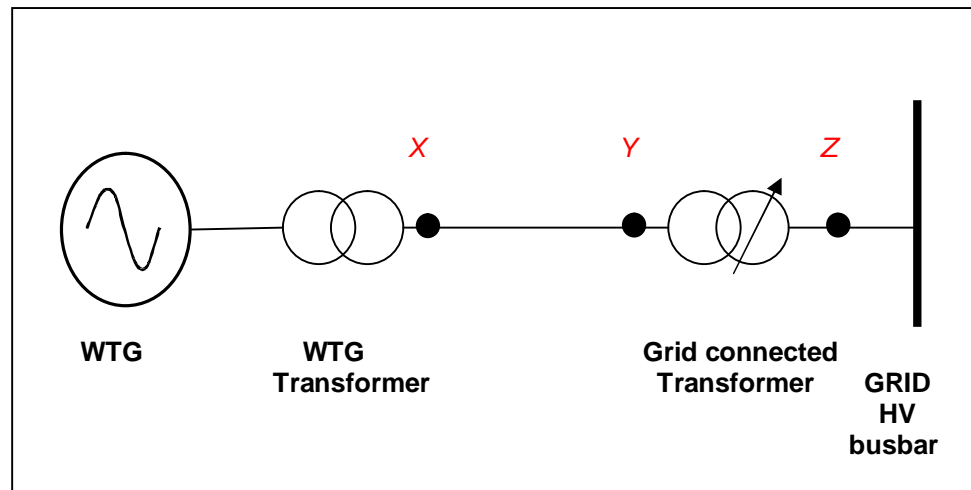

*Figure WFPS1.3 - Locations for **Voltage Regulation** set-point (Z) and the **Power Factor** range (Y). The HV side of the **WTG** transformer is (X).*

### WFPS1.6.3 REACTIVE POWER CAPABILITY

WFPS1.6.3.1 **Controllable WFPSs** shall be capable of operating at any point within the **Power Factor** ranges illustrated in *Figure WFPS1.4*, as measured at the lower voltage side of the **Grid Connected Transformer** (point Y in *Figure WFPS1.3*).

The design reference voltage for the **Reactive Power** capability shall be the nominal voltage at point Y.

The **Grid Connected Transformer** tap changing range must be capable of ensuring nominal voltage at point Y for any **Voltage** at the **Connection Point** (Point Z) within the ranges specified in WFPS1.6.1.

WFPS1.6.3.2 For **Controllable WFPSs** where the **Connection Point** is remote from the **Grid Connected Transformer**, any supplementary **Reactive Power** compensation required to offset the **Reactive Power** demand of the HV line, or cable, between the **Connection Point** and the **Controllable WFPS** shall be identified during the **TSO's Connection Offer** process.

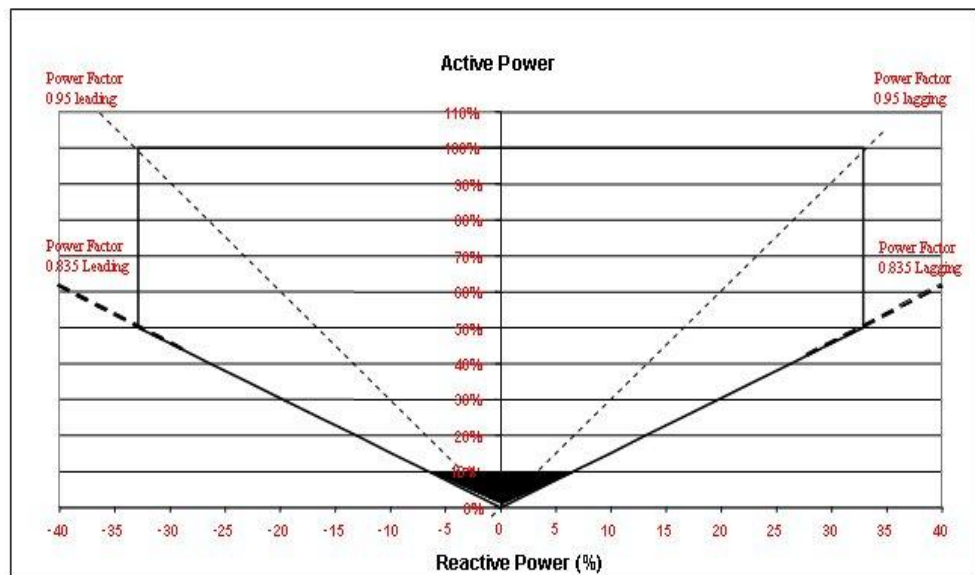

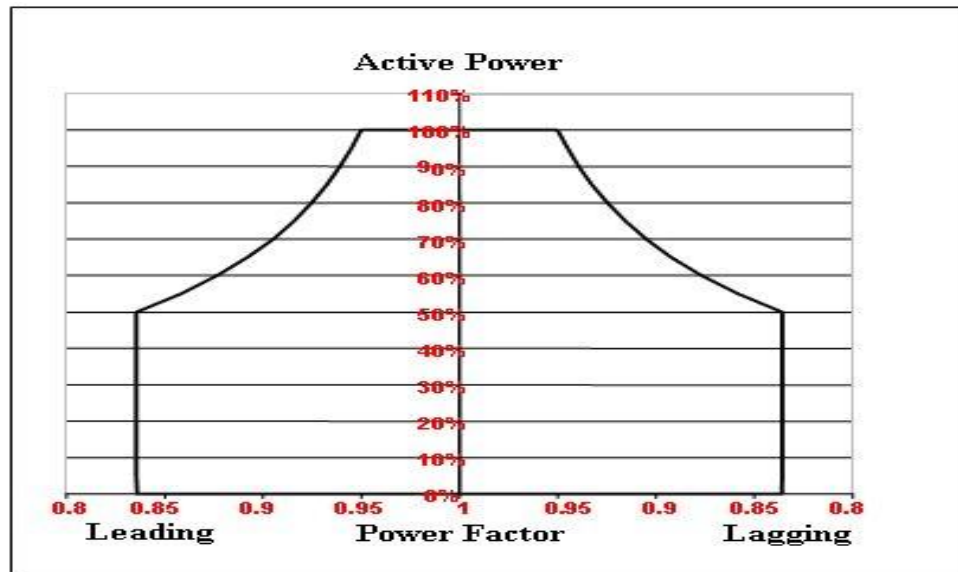

Figure WFPS1.4 - Reactive Power Capability of Controllable WFPS

WFPS1.6.3.3 For operation below 10 % of the **Controllable WFPS's MEC**, the **Controllable WFPS** shall operate within the shaded triangle in *Figure WFPS1.4*. However, if this cannot be achieved, then the total charging of the **Controllable WFPS** network during low load operation (below 10 %) shall be examined during the **TSO's Connection Offer** process. If during this examination it is identified that this charging may cause the voltage on the **Transmission System** to be outside the **Transmission System Voltage** ranges, as specified in WFPS1.6.1, then the **Reactive Power** requirements will need to be altered.

#### WFPS1.6.4 VOLTAGE STEP EMISSIONS

IEC 61000-3-7:1996 *Assessment of Emission limits for fluctuating loads in MV and HV power systems*, gives a table of the emission limits for **Voltage** changes as a function of the number of changes, R, per hour. This standard shall also apply to **Controllable WFPSs**.

#### WFPS1.6.5 CONTROLLABLE WFPS'S GRID CONNECTED TRANSFORMER

WFPS1.6.5.1 All relevant references in the **Grid Code to Generator Transformers** shall be interpreted to mean the **Controllable WFPS's Grid Connected Transformer** rather than the individual **WTG** transformers. For **Controllable WFPSs** where the **Connection Point** is remote from the **Controllable WFPS**, **Grid Connected Transformer** shall be interpreted to mean the HV transformer located at the **Controllable WFPS**.

WFPS1.6.5.2 **Controllable WFPSs** shall provide on-load tap-changing (OLTC) facilities for all **Grid Connected Transformers**. All **Controllable WFPSs** shall liaise with the **TSO** on the design specification for the performance of the tap-changing facility of the **Grid Connected Transformer**.

WFPS1.6.5.3 The **Controllable WFPS's Grid Connected Transformers** may be connected either:

- (a) in delta on the lower voltage side and in star (with the star point or neutral brought out) on the HV side; or
- (b) in star on both HV and lower voltage sides with a delta tertiary winding provided.

## **WFPS1.7 SIGNALS, COMMUNICATIONS & CONTROL**

### **WFPS1.7.1 SIGNALS FROM THE CONTROLLABLE WFPS TO THE TSO**

Signals from **Controllable WFPSs** to the **TSO** shall be broken up into a number of logical groups. There shall be different requirements for **Controllable WFPSs** depending on the **Controllable WFPS's MEC**. The following groups shall apply:

§ **Signals List #1** - applies to **all Controllable WFPSs**;

In addition, **Controllable WFPSs** shall be required to provide signals from *Signals Lists 2, 3, 4 and/or 5*. These lists relate to:

§ **Signals List #2** - Meteorological Data;

§ **Signals List #3** - **Availability** Data;

§ **Signals List #4** - **Active Power Control** Data;

§ **Signals List #5** - **Frequency Response System** Data.

#### **WFPS1.7.1.1 Signals List #1**

The **Controllable WFPS** shall make the following signals available at the designated **TSO Telecommunication Interface Cabinet** for that **Controllable WFPS**:

- a) **Active Power** output (MW) at the lower voltage side of the **Grid Connected Transformer**;
- b) **Reactive Power** output/demand (+/-Mvar) at the lower voltage side of the **Grid Connected Transformer**;
- c) Voltage (in kV) at the lower voltage side of the **Grid Connected Transformer**;
- d) **Available Active Power** (MW) at the lower voltage side of the **Grid Connected Transformer**;
- e) **Grid Connected Transformer** tap positions;
- f) **Voltage Regulation Set-point** (in kV);
- g) On/off status indications for all **Reactive Power** devices exceeding 5 Mvar<sup>1</sup>;

---

<sup>1</sup> Typically the position indication from capacitor/ SVC circuit breakers

- h) Circuit-breaker and disconnect position indication shall be required. These may include indications from MV circuit-breakers on individual **WTG** circuits. Signals from individual **WTG** circuit-breakers shall not be required. The actual circuit-breaker and disconnect signals required shall be specified by the **TSO** at least 120 **Business Days** prior to the **Controllable WFPS's** scheduled **Operational Date**;
- i) A minimum of four sets of normally open potential free auxiliary contacts in each **Grid Connected Transformer** lower voltage bay for fault indications; and
- j) On/off status of **TSO** remote control enable switch, which disables the ability of the **TSO** to send commands to the **Controllable WFPS**.

For the **Controllable WFPS's** where the Connection Point is at the HV side of the **Grid Connected Transformer**, signals a), b) and c) above will also be required from the HV side of the **Grid Connected Transformer**.

#### **WFPS1.7.1.2 Signals List #2**

WFPS1.7.1.2.1 **Controllable WFPSs** with a **MEC** in excess of 10 MW shall make the following meteorological data signals available at the designated **TSO Telecommunication Interface Cabinet** for that **Controllable WFPS**:

	<u>[Units, Range]</u>
a) Wind speed (at hub height) - measurand signal;	[m/s, 0-70]
b) Wind direction (at hub height) - measurand signal;	[deg, 0-360]
c) Air temperature- measurand signal;	[deg C, -40-70]
d) Air pressure- measurand signal.	[mBar, 735-1060]

WFPS1.7.1.2.2 The meteorological data signals shall be provided by a dedicated **Meteorological Mast** located at the **Controllable WFPS** site or, where possible and preferable to do so, data from a means of the same or better accuracy. For **Controllable WFPSs** where the **WTG** are widely dispersed over a large geographical area and rather different weather patterns are expected for different sections of the **Controllable WFPS**, the meteorological data shall be provided from a number of individual **Meteorological Masts**, or where possible and preferable to do so, data from a source of the same or better reliability for groups of **WTG** (e.g. 1 set of meteorological data for each group of XX **WTG** within the **Controllable WFPS**). It is expected that **WTG** within an individual group shall demonstrate a high degree of correlation in **Active Power** output at any given time. The actual signals required shall be

specified by the **TSO** at least 120 **Business Days** prior to the **Controllable WFPS's** scheduled **Operational Date**.

### **WFPS1.7.1.3 Signals List #3**

WFPS1.7.1.3.1 **Controllable WFPSs** with a **MEC** in excess of 10 MW shall make the following signals available at the designated **TSO Telecommunication Interface Cabinet** for that **Controllable WFPS**:

- a) **Controllable WFPS Availability** (0-100 % signal);
- b) Percentage of **WTG** shutdown due to high wind-speed conditions (0-100 %);
- c) Percentage of **WTG** not generating due low wind-speed shutdown (0-100 %).

WFPS1.7.1.3.2 For **Controllable WFPSs** with a **MEC** in excess of 10 MW, where the **WTG** are widely dispersed over a large geographical area and rather different weather patterns are expected for different sections of the **Controllable WFPS**, the above data set (ref. WFPS1.7.1.3.1) shall be provided for a number of groups of **WTG** (e.g. 1 signal for each group of XX **WTG** within the **Controllable WFPS**). It is expected that **WTG** within an individual group shall demonstrate a high degree of correlation in **Active Power** output at any given time. The actual signals required shall be specified by the **TSO** at least 120 **Business Days** prior to the **Controllable WFPS's** scheduled **Operational Date**.

### **WFPS1.7.1.4 Signals List #4**

The **Controllable WFPS** shall make the following signals available at the designated **TSO Telecommunication Interface Cabinet** for that **Controllable WFPS**:

- a) **Controllable WFPS Active Power Control Set-point** value (MW);
- b) **Controllable WFPS Active Power Control** status indication (ON/OFF).

### **WFPS1.7.1.5 Signals List #5**

The **Controllable WFPS** shall make the following signals available at the designated **TSO Telecommunication Interface Cabinet** for that **Controllable WFPS**:

- a) **Frequency Response System** mode signal (i.e. *Power-Frequency Response Curve 1 or 2*);
- b) **Frequency Response System** status indication (ON/OFF).

#### **WFPS1.7.1.6 Time Delays and Data Quality**

WFPS1.7.1.6.1 Digital signal changes from the **Controllable WFPS** shall be relayed to the **TSO Telecommunication Interface Cabinet** within 1 second of the associated change of state event. Analogue signal changes shall be relayed within 5 seconds and with an error of 0.5% or less, with the exception of the Meteorological Data required as per **WFPS1.7.1.2.1**, which shall be updated within 5 seconds and with an error of 2.5% or less.

#### **WFPS1.7.2 CONTROL SIGNALS FROM THE TSO TO CONTROLLABLE WFPS**

WFPS1.7.2.1 The control signals described in WFPS1.7.2 shall be sent from the **TSO** to the **Controllable WFPS**. The **Controllable WFPS** shall be capable of receiving these signals and acting accordingly.

##### **WFPS1.7.2.2 Active Power Control**

An **Active Power Control Set-point** signal shall be sent by the **TSO** to the **Wind Farm Control System**. This set-point shall define the maximum **Active Power** output permitted from the **Controllable WFPS**. The **Wind Farm Control System** shall be capable of receiving this signal and acting accordingly to achieve the desired change in **Active Power** output. This signal shall be in the form of a single analogue value and a strobe pulse to enable.

The **Controllable WFPS** is required to make it possible for the **TSO** to remotely enable/ disable the **Active Power Control** function in the **Wind Farm Control System**. The associated status indication is described in WFPS1.7.1.4.

##### **WFPS1.7.2.3 Frequency Response**

This signal shall be sent by the **TSO** to the **Controllable WFPS** in the event that a change from *Power-Frequency Response Curve 1* to *Power Frequency Response Curve 2*, or vice versa, is required.

The **Controllable WFPS** is required to make it possible for the **TSO** to remotely enable/ disable the **Frequency Response System**. The associated status indication is described in WFPS1.7.1.5.

##### **WFPS1.7.2.4 Voltage Regulation**

This signal shall allow the **TSO** to send a **Voltage Regulation Set-point** for **Voltage Regulation** purposes. This signal shall be in the form of a single analogue value and a strobe pulse to enable.

#### WFPS1.7.2.5 **Black Start Shutdown**

Means shall be provided by the **Controllable WFPS** to facilitate the disconnection of the **Controllable WFPS** by the **TSO** and to also prevent re-connection in the event of **Black Start**. The **TSO** shall send a **Black Start Shutdown** signal and upon receipt, the **Controllable WFPS** shall be required to trip the circuit-breaker(s) at the **Controllable WFPS's Connection Point** and shutdown the **Controllable WFPS** in a controlled manner. The precise circuit-breakers for which this facility shall be provided shall be specified by the **TSO** at least 120 **Business Days** prior to the **Controllable WFPS's** scheduled **Operational Date**. **Controllable WFPSs** may only be reconnected (i.e. made live) when the **Network** is fully restored following instruction from the **TSO**<sup>2</sup> and only earlier if the **TSO** deems it acceptable to do so.

#### WFPS1.7.2.6 **Time Delays and Data Quality**

WFPS1.7.2.6.1 Digital output commands from the **TSO Telecommunication Interface Cabinet** shall be relayed to the **Controllable WFPS** equipment within 1 second. Set-point output signals shall be relayed within 5 seconds and with an error of 0.5% or less.

#### WFPS1.7.3 **RESPONSIBLE OPERATOR**

A designated **Responsible Operator** shall be contactable by the **TSO** at all times to discuss operational matters without undue delay and in any case within 15 minutes. Following a request from the **TSO**, the **Responsible Operator** shall be present at the **Controllable WFPS's Connection Point** without undue delay and in any case within one hour and shall be capable of taking any required appropriate actions. The **Responsible Operator** shall be contactable 24 hours a day, 365 days a year.

#### WFPS1.7.4 **DATA AND COMMUNICATIONS SPECIFICATIONS**

WFPS1.7.4.1 The location of the **TSO Telecommunication Interface Cabinet** shall be agreed between the **TSO** and the **Controllable WFPS** at least 120 **Business Days** prior to the **Controllable WFPS's** scheduled **Operational Date**. A

---

<sup>2</sup> Typically this instruction will be in the form of a Blackstart Shutdown OFF command

standard interface for signals will be made available to the **Controllable WFPS** by the **TSO**.

WFPS1.7.4.2 The necessary communications links, communications protocol and an individual **Controllable WFPS** signal list shall be specified by the **TSO** at least 120 **Business Days** prior to the **Controllable WFPS's** scheduled **Operational Date**. Current applicable standards shall apply and the accuracy class for signals shall comply with the prevailing European Standard at that time.

WFPS1.7.4.3 For loss of communications links, persistence (i.e. continuing to operate with the most recent data set) shall be used in terms of set-points until the designated **Responsible Operator** has been contacted by the **TSO**.

WFPS1.7.4.4 If **Active Power Control, Frequency Response** or **Voltage Regulation** facilities for the **Controllable WFPS** become unavailable, the **Controllable WFPS** shall contact the **TSO** without undue delay.

WFPS1.7.4.5 Where signals or indications required to be provided by the **Controllable WFPS** under WFPS1.7.1 and WFPS 1.7.2 become unavailable or do not comply with applicable standards due to failure of the **Controllable WFPS's** technical equipment or any other reason under the control of the **Controllable WFPS**, the **Controllable WFPS** shall, acting in accordance with **Good Industry Practice**, restore or correct the signals and/or indications as soon as possible.

#### **WFPS1.7.5 WIND POWER FORECASTS**

WFPS1.7.5.1 Should the **TSO** determine that wind power forecasts as produced by the **Controllable WFPS** are required, the **TSO** shall inform the **Controllable WFPS** and the wind power forecasts shall be provided by the **Controllable WFPSs**. These forecasts, if required, shall be provided in a format and timescale as specified by the **TSO**, and by means of an **Electronic Interface** in accordance with the reasonable requirements of the **TSO's** data system.

WFPS1.7.5.2 **Controllable WFPSs** shall engage fully with the **TSO** to ensure that the necessary information is available to the **TSO** for the production of wind generation forecasts with the appropriate level of accuracy by the **TSO**. Where this engagement involves the provision of data by the **Controllable WFPS** to the **TSO**, this data must be provided as soon as reasonably practicable, or in any event, within 60 business days of the date of the request.

#### **WFPS1.7.6 CONTROLLABLE WFPS MW AVAILABILITY DECLARATIONS**

**Controllable WFPSs** shall submit **Controllable WFPS MW Availability Declarations** whenever changes in **Controllable WFPS Availability** occur or are predicted to occur. These declarations shall be submitted by means of an **Electronic Interface** in accordance with the reasonable requirements of the **TSO's** data system.