

Application Form for Connection of

Generation Facilities

to the Transmission System

Please note that wind generation has a separate application form.

INTRODUCTION

This application form (version 1.1) outlines the information EirGrid requires to progress an application for connection to the Transmission System. EirGrid recommends that the applicant read “Process for Connection” published on our website, www.eirgrid.com. This document describes the connection offer process and sets out the associated application processing fees. The website has links to other relevant documents such as the Grid Code. It should be noted that it is the applicant’s responsibility to comply with the technical, design and operational standards detailed in the Grid Code.

Please note for the purpose of this application form TSO should be interpreted as: The holder of the license to operate Ireland’s Transmission System (EirGrid).

Please note that this application form deals with HV connections only (≥ 110 kV) and that if an MV (< 110 kV) supply is required the applicant should contact ESB Networks:
Tel: +353 850 372 757, www.esb.ie.

EirGrid reserves the right to request additional data if necessary and the applicant should provide such information promptly during and post the offer process.

It is EirGrid’s responsibility to determine the transmission connection method; if the applicant has a specific request this will be considered and examined in the process. The selected method will be based on the overall least cost technically acceptable solution unless the Applicant requests otherwise or EirGrid requires an alternative method for system reasons.

Definitions of terms used in this form can be found in the Glossary of the Grid Code.

The following information will be disclosed in the Interactions List found on www.eirgrid.com once the application is deemed fully complete by EirGrid.

- Applicant details (contact name, email address, telephone number).
- Application complete date.
- Status of application.
- Grid co-ordinates of electrical connection point.
- Capacity of Project (MW).
- Interacting group where applicable (with all of the above details available separately for each member of the group).

When the application form is completed please send the form to:

EirGrid
New Applications, Codes and Agreements
27 Lower Fitzwilliam Street
Dublin 2
Ireland

If any queries arise please do not hesitate to contact our Customer Relations Team.

Tel: +353 1 702 6642

Fax: +353 1 661 5375

email: info@eirgrid.com

DETAILS OF APPLICANT

1. Full name of the applicant(s)

2. Address of the applicant(s) or in the case of a corporate body, the registered address and company registration number

Company ref. no. (if applicable)

3. Telephone Number

4. Telefax Number

5. Contact Person(s)

6. Email Address

7. Contact Address (if different to above)

8. Please nominate a preferred name for this facility. The TSO will take this preferred name into consideration when determining the facilities station name but reserves the right to change it in order to avoid any potential for confusion with other projects or stations.

GENERAL DETAILS

9. It should be noted that it is the applicants responsibility to comply with the technical, design and operational standards detailed in the Grid Code.

Noted

10. Has the Applicant signed a confidentiality agreement with TSO?

If no, two copies have to be submitted with application form.

Confidentiality agreement templates can be found on our website, www.eirgrid.com.

Yes

No

11. Has the Applicant previously had a pre-feasibility study regarding this facility completed by TSO?

If yes, please specify name and the date of issue of the Pre-feasibility study(s).

Study 1:

 (D/M/Y)

Study 2:

 (D/M/Y)

12. Please note that EirGrid has processes in place for the procurement of Ancillary Services from generators.

These Ancillary Services include: Black Start, Operating Reserve, Reactive Power.

If you wish to learn more about this and the payments involved, please contact our Customer Relations Team.

Noted

MAPS AND DIAGRAMS

13. Please provide a 1:50,000 "Discovery Series" Ordnance Survey map, with the location of the facility clearly marked. The electrical connection point must be clearly marked with an "X".

Name of OS map attachment

Grid co-ordinates of the electrical connection point of your site (In appendix A an example is shown of how to correctly specify the grid co-ordinates):

Easting

Northing

14. Please provide a site plan in an appropriate scale. This site plan should indicate

- the proposed location of the connection point
- generators
- transformers
- site buildings

Note that the connection point is normally at the HV bushings of the grid connected transformer. Space for the transmission compound will have to be clearly marked on the site plan. The exact size of the compound will depend on the connection method defined in the connection offer. Site plan is to be submitted in both hard and soft copy.

Name of site plan attachment (soft copy)

Name of site plan attachment (hard copy)

15. Please provide an electrical Single Line Diagram (SLD) of the proposed facility detailing all significant items of plant and their values including:

- Relevant voltage levels
- Interlocking
- Earthing and synchronising arrangements
- Relay types
- CT/VT ratios
- Generator transformer(s)
- Power factor correction devices
- Location of alternative connection for house load (if applicable)
- Grid connected transformer(s)

The SLD is to be submitted in both hard copy and soft copy.

Name of the SLD attachment (soft copy)

Name of the SLD attachment (hard copy)

16. Please provide a functional block diagram of the main plant components, showing boilers, turbines, heat recovery boilers, alternators, any heat or steam supplies to other processes etc. The functional block diagram must indicate whether single or separate shaft is to be utilised in the case of CCGT.

Submitted

TECHNICAL DETAILS REQUIRED

GENERAL DATA

17. Target Connection Date (this date will be used for connection assesment)

 (D/M/Y)

18. Projected period from Target Connection Date to Operational Date: (X months)

TECHNICAL DETAILS REQUIRED

GENERAL DATA – CONTINUED

19. Maximum Export Capacity (MEC) required

This is the amount of exporting transmission capacity that will be provided for in the connection offer.

MW

20. State number of connecting circuits to the Transmission System (e.g. one, two etc.), the applicant requires for technical and/or security reasons.

21. Total number of generation units

22. Please provide details of the expected running regime. (e.g base load, peaking etc)

PLANT CAPABILITY DATA

Generator capabilities must comply with the Grid Code. Please review the connection conditions for a list of the required standards.

	Unit 1	Unit 2	Unit 3
23. Type of generation plant (hydro, combined cycle, combustion turbine, steam turbine, gas turbine etc.)	_____	_____	_____
24. Primary Fuel Source	_____	_____	_____
25. Secondary Fuel Source	_____	_____	_____
26. Manufacturer of generator	_____	_____	_____
27. Model and type of above generator	_____	_____	_____
28. Type of generator (synchronous, asynchronous, etc.)	_____	_____	_____
29. Number of generators of type	_____	_____	_____
30. Generator voltage (kV)	_____	_____	_____
31. Generator rated MVA	_____	_____	_____
32. Maximum continuous generation capacity at normal operating air conditions ¹ (MW)	_____	_____	_____
33. Maximum continuous export capacity at normal operating air conditions ¹ (MW)	_____	_____	_____
34. Maximum continuous generation capacity at minimum ambient air conditions (MW)	_____	_____	_____
35. Maximum continuous export capacity at minimum ambient air conditions (MW)	_____	_____	_____
36. Ambient air conditions in question 34 and 35 are based on (°C, bar, % humidity)	_____	_____	_____

¹ Normal operating air conditions to be assumed = 10°C, 1.01bar, 70% humidity

TECHNICAL DETAILS REQUIRED

PLANT CAPABILITY DATA – CONTINUED

	Unit 1	Unit 2	Unit 3
37. Minimum continuous generating capacity (MW)	_____	_____	_____
38. Minimum continuous export capacity (MW)	_____	_____	_____

39. If the Maximum continuous export capacity of the plant is affected by the ambient air temperature, please provide a Maximum continuous export capacity (MW) vs ambient air temperature chart for the plant covering at least the range -5°C to 25°C.

Name of the attachment

40. Is it possible for the plant to provide additional peaking capacity on a short term basis?

No Yes (If yes, please provide details)

Name of attachment detailing additional peaking capacity:

41. Please provide a reactive power capability curve for the entire active power operating range for each generator as provided at the alternator terminals and at normal operating air conditions¹. Please note that the reactive power capability of each generator must be compliant with Grid Code ref: CC.7.3.6.

Name of reactive power capability diagram attachment(s)

42. Please state the power factor ranges of each unit as provided at the alternator terminals and at normal operating air conditions at the specified active power percentages of the maximum continuous export capacity and then specify the equivalent Mvar capability.

		35%		100%	
		Ind.	Cap.	Ind.	Cap.
Unit 1	Power Factor of Generators				
	Equivalent Mvar				
Unit 2	Power Factor of Generators				
	Equivalent Mvar				
Unit 3	Power Factor of Generators				
	Equivalent Mvar				

¹ Normal operating air conditions to be assumed = 10°C, 1.01bar, 70% humidity

TECHNICAL DETAILS REQUIRED

GRID CONNECTED TRANSFORMER DATA

There are many types of transformers. This application form specifies two and three winding transformers. Please fill in relevant section. All impedances should be stated in % on transformer MVA base.

Please note that the connection voltage is determined by EirGrid in accordance with normal standards as detailed in the Grid Code taking into account the particulars of each development. If the connection voltage differs to that specified in the Application, EirGrid will request new data corresponding to the new voltage level. An appropriate connection voltage will initially be examined as part of the application check.

Please note the Grid Connected Transformer specified must be compliant with sections CC.7.2.5 & CC.7.3.9 of the Grid Code.

Please note that a full manufacturer’s test report will be required at a later stage. Noted

43. State number of transformers proposed at the electrical connection point(s).

TWO WINDING TRANSFORMERS

	Transformer 1	Transformer 2	Transformer 3
44. Transformer rated MVA			
45. Temperature above rating is based on (°C)			
46. Transformer voltage ratio HV/LV (kV)			
47. Transformer positive sequence resistance (R ₁ %)			
48. Transformer positive sequence reactance (X ₁ %)			
49. Transformer zero sequence resistance (R ₀ %)			
50. Transformer zero sequence reactance (X ₀ %)			
51. Transformer vector group			
52. Please provide details of tap changer. Nature of tap changer (off load/on load/off circuit)			

Transformer 1:	Tapped voltage winding	<input type="text"/> kV	+	<input type="text"/> Steps	-	<input type="text"/> Steps	<input type="text"/> %	Step Size
Transformer 2:	Tapped voltage winding	<input type="text"/> kV	+	<input type="text"/> Steps	-	<input type="text"/> Steps	<input type="text"/> %	Step Size
Transformer 3:	Tapped voltage winding	<input type="text"/> kV	+	<input type="text"/> Steps	-	<input type="text"/> Steps	<input type="text"/> %	Step Size

THREE WINDING TRANSFORMERS

Transformer 1	HV winding	LV1 winding	LV2 winding
53. Transformer rated MVA			
54. Temperature above rating is based on (°C)			
55. Transformer rated voltage (kV)			
56. Transformer vector group			
Transformer 2			
57. Transformer rated MVA			
58. Temperature above rating is based on (°C)			
59. Transformer rated voltage (kV)			
60. Transformer vector group			

TECHNICAL DETAILS REQUIRED

GRID CONNECTED TRANSFORMER DATA – CONTINUED

Clearly specify the MVA base (in space provided between brackets) which the measured impedances below are related to

	Transformer 1	Transformer 2
61. Transformer positive sequence resistance (R _{1HL1} %) between HV/LV1:	<input type="text"/> ()	<input type="text"/> ()
62. Transformer positive sequence reactance (X _{1HL1} %) between HV/LV1:	<input type="text"/> ()	<input type="text"/> ()
63. Transformer zero sequence resistance (R _{0HL1} %) between HV/LV1:	<input type="text"/> ()	<input type="text"/> ()
64. Transformer zero sequence reactance (X _{0HL1} %) between HV/LV1:	<input type="text"/> ()	<input type="text"/> ()
65. Transformer positive sequence resistance (R _{1HL2} %) between HV/LV2:	<input type="text"/> ()	<input type="text"/> ()
66. Transformer positive sequence reactance (X _{1HL2} %) between HV/LV2:	<input type="text"/> ()	<input type="text"/> ()
67. Transformer zero sequence resistance (R _{0HL2} %) between HV/LV2:	<input type="text"/> ()	<input type="text"/> ()
68. Transformer zero sequence reactance (X _{0HL2} %) between HV/LV2:	<input type="text"/> ()	<input type="text"/> ()
69. Transformer positive sequence resistance (R _{1L1L2} %) between LV1/LV2:	<input type="text"/> ()	<input type="text"/> ()
70. Transformer positive sequence reactance (X _{1L1L2} %) between LV1/LV2:	<input type="text"/> ()	<input type="text"/> ()
71. Transformer zero sequence resistance (R _{0L1L2} %) between LV1/LV2:	<input type="text"/> ()	<input type="text"/> ()
72. Transformer zero sequence reactance (X _{0L1L2} %) between LV1/LV2:	<input type="text"/> ()	<input type="text"/> ()
73. Transformer positive sequence resistance (R _{1HL1L2} %) between HV/(LV1+LV2):	<input type="text"/> ()	<input type="text"/> ()
74. Transformer positive sequence reactance (X _{1HL1L2} %) between HV/(LV1+LV2):	<input type="text"/> ()	<input type="text"/> ()
75. Transformer zero sequence resistance (R _{0HL1L2} %) between HV/(LV1+LV2):	<input type="text"/> ()	<input type="text"/> ()
76. Transformer zero sequence reactance (X _{0HL1L2} %) between HV/(LV1+LV2):	<input type="text"/> ()	<input type="text"/> ()
77. Please provide details of tap changer. Nature of tap changer (off load/on load/off circuit):		

Transformer 1:	Tapped voltage winding	<input type="text"/> kV	+	<input type="text"/> Steps	-	<input type="text"/> Steps	<input type="text"/> %	Step Size
Transformer 2:	Tapped voltage winding	<input type="text"/> kV	+	<input type="text"/> Steps	-	<input type="text"/> Steps	<input type="text"/> %	Step Size

TECHNICAL DETAILS REQUIRED

STATION DATA

78. Please specify the Maximum Import Capacity (MIC) required. This is the amount of Import Capacity that the site will require during start up and will be provided in the connection offer.

MVA

79. Please specify the house load required for the site under normal operating conditions

MW MVA_r

80. Please state if a separate transmission connection is required to supply house load

Yes No If yes, please submit details.

Name of attachment:

GENERATION DATA FOR FAULT STUDIES (SHORT CIRCUIT)

	Unit 1	Unit 2	Unit 3
81. X_d' – Generator Direct Axis Transient Reactance (unsaturated): (pu on machine MVA base)	<input type="text"/>	<input type="text"/>	<input type="text"/>
82. X_d' – Generator Direct Axis Transient Reactance (saturated): (pu on machine MVA base)	<input type="text"/>	<input type="text"/>	<input type="text"/>
83. X_d'' – Generator Sub-transient Reactance (unsaturated): (pu on machine MVA base)	<input type="text"/>	<input type="text"/>	<input type="text"/>
84. X_d'' – Generator Sub-transient Reactance (saturated): (pu on machine MVA base)	<input type="text"/>	<input type="text"/>	<input type="text"/>
85. X_2 – Generator Negative Phase Sequence Synchronous Reactance: (pu on machine MVA base)	<input type="text"/>	<input type="text"/>	<input type="text"/>
86. X_0 – Generator Zero Phase Sequence Reactance: (pu on machine MVA base)	<input type="text"/>	<input type="text"/>	<input type="text"/>

DYNAMIC SIMULATION DATA

GENERATOR DATA

Please note that exact information and parameters regarding excitation, governor systems and power system stabiliser will be required at the time of commissioning.

Noted

	Unit 1	Unit 2	Unit 3
87. X_d – Generator Direct Axis Positive Phase Sequence Synchronous Reactance: (pu machine MVA base)	<input type="text"/>	<input type="text"/>	<input type="text"/>

DYNAMIC SIMULATION DATA

GENERATOR DATA – CONTINUED

88. X_q – Generator Quadrature Axis Positive Phase Sequence Synchronous Reactance: (pu machine MVA base)	<input type="text"/>	<input type="text"/>	<input type="text"/>
89. X_d' – Generator Direct Axis Transient Reactance (unsaturated): (pu machine MVA base)	<input type="text"/>	<input type="text"/>	<input type="text"/>
90. X_q' – Generator Quadrature Axis Transient Reactance (unsaturated): (pu machine MVA base) (Note: Not applicable to induction generators).	<input type="text"/>	<input type="text"/>	<input type="text"/>
91. X_d'' – Generator Sub-transient Reactance (unsaturated): (pu machine MVA base)	<input type="text"/>	<input type="text"/>	<input type="text"/>
92. X_l – Armature Leakage Reactance: (pu machine MVA base)	<input type="text"/>	<input type="text"/>	<input type="text"/>
93. T_{do}' – Generator Direct Axis Transient Open Circuit Time Constant: (Sec)	<input type="text"/>	<input type="text"/>	<input type="text"/>
94. T_{do}'' – Generator Direct Axis Subtransient Open Circuit Time Constant: (Sec)	<input type="text"/>	<input type="text"/>	<input type="text"/>
95. T_{qo}' – Generator Quadrature Axis Transient Open Circuit Time Constant: (Sec)	<input type="text"/>	<input type="text"/>	<input type="text"/>
96. T_{qo}'' – Generator Quadrature Axis Subtransient Open Circuit Time Constant: (Sec)	<input type="text"/>	<input type="text"/>	<input type="text"/>
97. H – Inertia of complete turbogenerator including prime-mover gearbox if fitted (MWs/MVA)	<input type="text"/>	<input type="text"/>	<input type="text"/>

98. Please submit the open-circuit generator magnetic saturation curve. If this data is not available at this stage EirGrid will assume the magnetic saturation characteristics for the generator to be in accordance with Appendix B.

Complete the following section as appropriate:

Please assume generator magnetic saturation curve as per appendix B

OR

Please assume other generator magnetic saturation curve

Name of attachment specifying curve:

EXCITATION SYSTEM

99. Please submit a Laplace-domain control block diagram that represents the generator excitation system in accordance with IEEE standard excitation models or as otherwise agreed with EirGrid. This control block diagram should specify all time constants and gains to fully explain the transfer function from the compensator or generator terminal voltage and field current to generator field voltage. A list of acceptable IEEE standard excitation models available within the PSS/E simulation package used by EirGrid is shown in Appendix C.

Complete the following section as appropriate:

A. Please assume _____ model from Appendix C.

Name of attachment detailing the data parameters for the specified excitation model:

OR

DYNAMIC SIMULATION DATA

EXCITATION SYSTEM – CONTINUED

B. Please assume other model

Name of attachment specifying model and all necessary data parameters: _____

OR

C. If excitation system data is not available at this stage EirGrid will assume a standard model with corresponding parameters for the excitation system. The assumed exciter model for dynamic simulation is detailed in Appendix D.

Please assume the model detailed in Appendix D as our excitation system.

POWER SYSTEM STABILISER (PSS)

100. Please note that full details relating to the Power system stabiliser (PSS) and its dynamic models will be requested at a later date.

Noted

GOVERNOR SYSTEM

101. Please submit a Laplace-domain control block diagram that represents the generator’s turbine-governor system in accordance with IEEE standard turbine-governor models or as otherwise agreed with EirGrid. This control block diagram should specify all time constants and gains to fully explain the transfer function from the compensator or generator terminal voltage and field current to generator field voltage. A list of acceptable IEEE standard turbine-governor models available within the PSS/E simulation package used by EirGrid is shown in Appendix E

Complete the following section as appropriate:

A. Please assume _____ model from Appendix E

Name of attachment detailing the data parameters for the specified turbine-governor model: _____

OR

B. Please assume other model

Name of attachment specifying model and all necessary data parameters: _____

OR

C. If turbine-governor system data is not available at this stage EirGrid will assume a standard model with corresponding parameters for the turbine-governor system. The assumed turbine-governor model for dynamic simulation is detailed in Appendix F

Please assume the model detailed in Appendix F as our turbine-governor system.

APPENDIX A

HOW TO DERIVE THE GRID CO-ORDINATES FROM “DISCOVERY SERIES” ORDNANCE SURVEY MAP

Easting and Northing co-ordinates should be stated to six places. Easting co-ordinates are the numbers on the horizontal axis. Northing co-ordinates are the numbers on the vertical axis.

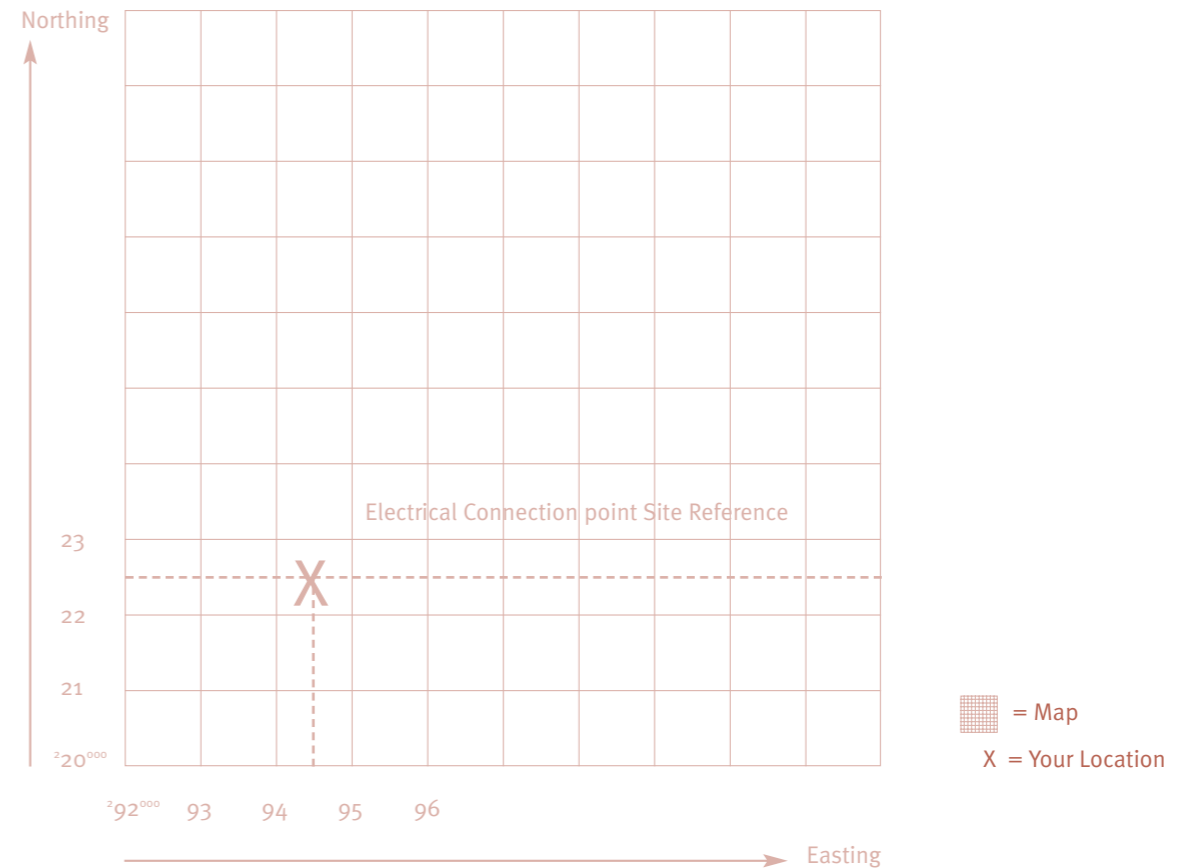

FIGURE 1. EXAMPLE OF A DISCOVERY SERIES MAP GRID

Site co-ordinates: Easting 294500, Northing 222500

EXAMPLE

The electrical connection point Easting co-ordinates are QYYZZZ.

Q refers to the first number (in superscript) of the bottom left hand corner of the map (i.e. 292000 Q=2), YY are the numbers on the horizontal axis directly below the site to the left (i.e. 94). ZZZ is the actual position in the grid expressed from 0 to 999 (e.g. if half way horizontally within the grid square, the Easting number is approximately 500).

The Northing co-ordinates are similarly identified, except that the numbers refer to the vertical axis.

APPENDIX B

GENERATOR MAGNETIC SATURATION CURVES

p.u. Saturation Function $S(x)$

$$S(1.0)=0.10$$

$$S(1.2)=0.33$$

The saturation function is defined in terms of the open terminal voltage versus field current characteristics shown below in Figure 1. From this figure we define

$$S(1.2)=(A_{1.2}-B_{1.2})/B_{1.2}$$

$$S(1.0)=(A_{1.0}-B_{1.0})/B_{1.0}$$

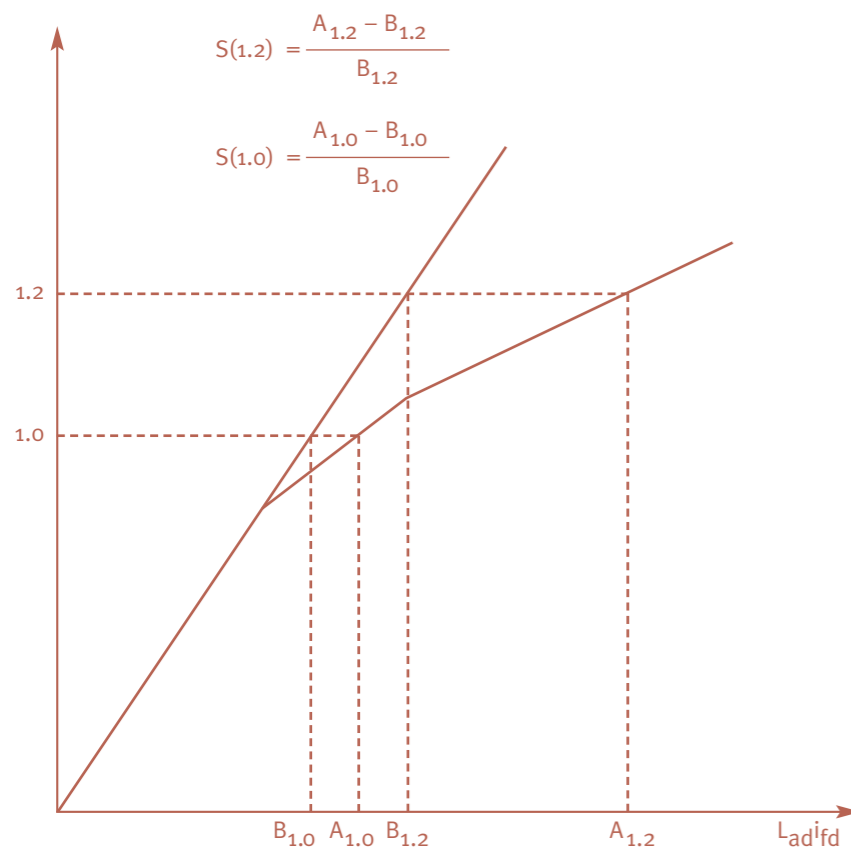

FIGURE 2. GENERATOR MAGNETIC SATURATION CURVES

APPENDIX C

EXCITATION SYSTEM MODELS

Below is a list of the standard excitation system models contained in the PSS/E dynamics model library.

- ESAC1A** 1992 IEEE type AC1A excitation system model
- ESAC2A** 1992 IEEE type AC2A excitation system model
- ESAC3A** 1992 IEEE type AC3A excitation system model
- ESAC4A** 1992 IEEE type AC4A excitation system model
- ESAC5A** 1992 IEEE type AC5A excitation system model
- ESAC6A** 1992 IEEE type AC6A excitation system model
- ESAC8B** Basler DECS model
- ESDC1A** 1992 IEEE type DC1A excitation system model
- ESDC2A** 1992 IEEE type DC2A excitation system model
- ESST1A** 1992 IEEE type ST1A excitation system model
- ESST2A** 1992 IEEE type ST2A excitation system model
- ESST3A** 1992 IEEE type ST3A excitation system model
- ESST4B** IEEE type ST4B potential or compounded source-controlled rectifier exciter
- EX2000** EX2000 Excitation System
- EXAC1** 1981 IEEE type AC1 excitation system model
- EXAC1A** Modified type AC1 excitation system model
- EXAC2** 1981 IEEE type AC2 excitation system model
- EXAC3** 1981 IEEE type AC3 excitation system model
- EXAC4** 1981 IEEE type AC4 excitation system model
- EXBAS** Basler static voltage regulator feeding dc or ac rotating exciter model
- EXDC2** 1981 IEEE type DC2 excitation system model
- EXELI** Static PI transformer fed excitation system model
- EXPIC1** Proportional/integral excitation system model
- EXST1** 1981 IEEE type ST1 excitation system model
- EXST2** 1981 IEEE type ST2 excitation system model
- EXST2A** Modified 1981 IEEE type ST2 excitation system model
- EXST3** 1981 IEEE type ST3 excitation system model
- IEEET1** 1968 IEEE type 1 excitation system model
- IEEET2** 1968 IEEE type 2 excitation system model
- IEEET3** 1968 IEEE type 3 excitation system model
- IEEET4** 1968 IEEE type 4 excitation system model
- IEEET5** Modified 1968 IEEE type 4 excitation system model
- IEEEX1** 1979 IEEE type 1 excitation system model and 1981 IEEE type DC1 model
- IEEEX2** 1979 IEEE type 2 excitation system model
- IEEEX3** 1979 IEEE type 3 excitation system model
- IEEEX4** 1979 IEEE type 4 excitation system, 1981 IEEE type DC3 and 1992 IEEE type DC3A models
- IEET1A** Modified 1968 IEEE type 1 excitation system model
- IEET1B** Modified 1968 IEEE type 1 excitation system model
- IEET5A** Modified 1968 IEEE type 4 excitation system model
- IEEX2A** 1979 IEEE type 2A excitation system model
- SCRX** Bus or solid fed SCR bridge excitation system model
- SEXS** Simplified excitation system model
- URST5B** IEEE proposed type ST5B excitation system (obsolete)
- URST5T** IEEE proposed type ST5B excitation system

APPENDIX D

SHUNT FED EXCITATION MODEL WITH TYPICAL PARAMETERS

Figure 3 represents the excitation model assumed. Parameters are set so to bypass the negative current logic. SCR_X.

Value	Description
0.1	T _A /T _B
10	T _B (seconds)
200	K
0.05	T _E (seconds)
0	E _{MIN}
4	E _{MAX}
0	C _{SWITCH}

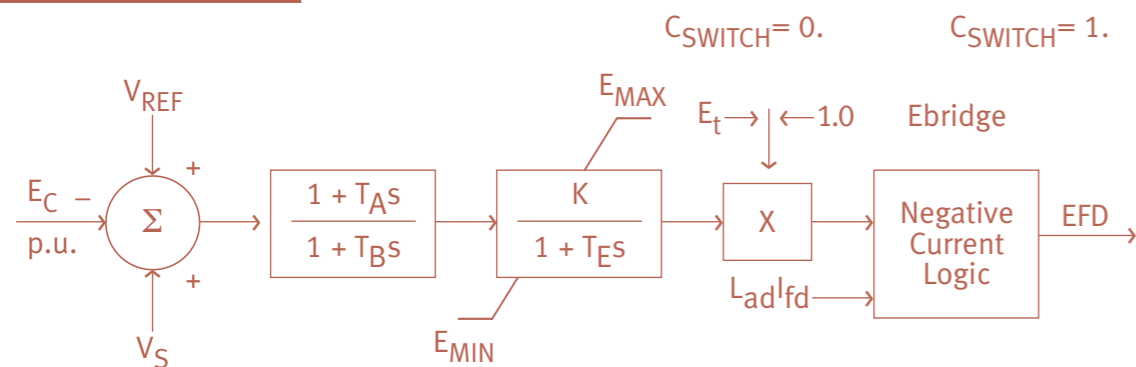

FIGURE 3: SIMPLE SHUNT FED EXCITATION MODEL

APPENDIX E

TURBINE-GOVERNOR SYSTEM MODELS

Below is a list of the standard turbine-governor models contained in the PSS/E dynamics model library.

- CRCMGV** Cross compound turbine-governor model
- DEGOV** Woodward diesel governor model
- DEGOV1** Woodward diesel governor model
- GAST** Gas turbine-governor model
- GAST2A** Gas turbine-governor model
- GASTWD** Gas turbine-governor model
- HYGOV** Hydro turbine-governor model
- IEEEG1** 1981 IEEE type 1 turbine-governor model
- IEEEG2** 1981 IEEE type 2 turbine-governor model
- IEEEG3** 1981 IEEE type 3 turbine-governor model
- IEESGO** 1973 IEEE standard turbine-governor model
- PIDGOV** Hydro turbine and governor model
- TGOV1** Steam turbine-governor model
- TGOV2** Steam turbine-governor model with fast valving
- TGOV3** Modified IEEE type 1 turbine-governor model with fast valving
- TGOV5** Modified IEEE type 1 turbine-governor model with boiler controls
- WEHGOV** Woodward electronic hydro governor model
- WESGOV** Westinghouse digital governor for gas turbine
- WPIDHY** Woodward P.I.D. hydro governor model

APPENDIX F

TURBINE-GOVERNOR MODEL WITH TYPICAL PARAMETERS

Figure 4 represents the turbine-governor model assumed. TGOV₁.

Value	Description
0.04	R
0.5	T ₁ (∞) seconds
0.85	V _{MAX}
0.2	V _{MIN}
2	T ₂ (∞) seconds
7	T ₃ (∞) seconds
0	D _t

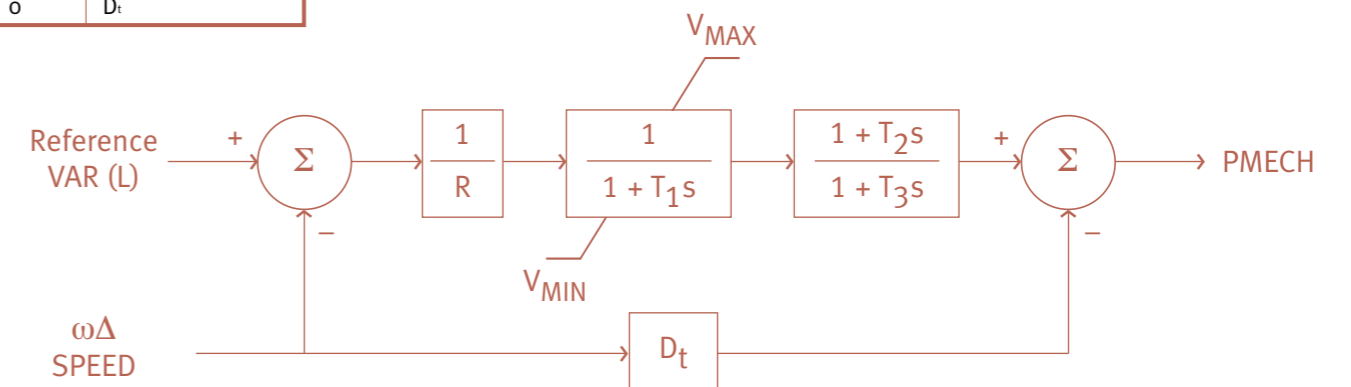

FIGURE 4: SIMPLE TURBINE-GOVERNOR MODEL

CHECKLIST

- Application form completed in full
- Application fee
- Two signed copies of a confidentiality agreement (if applicable)
- OS map
- SLD (hard and soft copy)
- Site plan (hard and soft copy)
- Functional Block Diagram of Plant
- MW output vs Ambient Temperature Chart (if applicable)
- Additional peaking capacity (if applicable)
- Reactive Power Capability Curve
- Station Data (if applicable)
- Open Circuit magnetic saturation curve (if applicable)
- Excitation system model (if applicable)
- Turbine governor system model (if applicable)