



Contestability of Connection Assets

October 16th 2007

TABLE OF CONTENTS

1. INTRODUCTION.....	5
2. CONTESTABLE TERMINOLOGY.....	7
2.1. RELATED DEFINITIONS	7
2.1.1. Applicant Provided Assets	7
2.1.2. Contestable Assets.....	7
2.1.3. Contestable Transmission Assets	7
2.1.5. Shallow Connection.....	7
2.1.6. Transmission System	8
2.1.7. TSO Provided Assets	8
2.2. GRAPHICAL REPRESENTATION OF DEFINITIONS	9
2.3. BOUNDARY DEFINITIONS.....	11
2.3.1. Construction Boundary.....	11
2.3.2. Ownership Boundaries	12
2.4. CONNECTION TYPES	13
2.4.1. Meshed Connection.....	13
2.4.2. Radial Connection Serving Multiple Applicants	14
2.4.3. Radial Connection Serving a Single Applicant	15
3. KEY PRINCIPLES.....	16
4. CONTESTABILITY & TSO ASSISTANCE TO APPLICANTS.....	17
4.1. PROCESS OF CONNECTION	17
4.1. CONTESTABLE TRANSMISSION ASSETS	18
4.1.1. Connection Method	18
4.1.2. Applicant Choice & execution of the connection agreement.....	18
4.1.3. Outline design and functional specification.....	19
4.1.4. Route and Site Selection	19
4.1.5. Planning Consents.....	20
4.1.6. Detailed Design, Procurement and Construction.....	20
4.1.7. Commissioning & first energisation.....	21
4.1.8. Ownership transfer of Assets	21
4.1.9. Operations & Maintenance.....	22
5. CONCLUSIONS.....	23
APPENDIX 1: OWNERSHIP BOUNDARY	25

Executive Summary

Contestability, the right of transmission connecting parties to construct part or all of their connection was introduced in Ireland via legislation in 2000¹. The first Contestable Connection was granted soon after following a Commission for Energy Regulation (CER) interpretation of the legislation. In an effort to formalise the process the Transmission System Operator (TSO), ESB National Grid, published a set of guidelines in March 2002 that underpins the current principles governing and procedures relating to contestability².

Since the publication of the guidelines experience has been gained by the TSO, TAO, CER and participants following the completion of a number of Contestable Connections. On foot of this experience the TSO believed that it would be prudent to review some of the elements of its March 2002 guidelines. The outcome of the review process was a consultation paper, “A review of Contestability, TSO position Paper”, dated January 2006, which proposed a number of changes to the 2002 guideline paper. This paper was published for consultation and the output of the review and the subsequent consultation process is reflected in this updated contestable guideline paper.

In general, contestable activities will include detailed design, routing, site selection, planning consents, wayleaves procurement and construction (subject to a given set of standards and TSO acceptance) for Contestable Assets*. Given the TSO's overall system responsibilities some elements of a Contestable Connection will be determined or arranged to be provided by the TSO.

The TSO will be responsible for design approval, certain inspection work, specifying the connection method and controlling the first energisation for assets which are supplied by the applicant, but may or may not be part of the Transmission system. The TSO will also be responsible for other non-contestable work not listed above.

The applicant must also provide written “Proof of Readiness” prior to connection of such assets to the Transmission System.

Certain activities, works and assets will in all cases be non-contestable, these include:

- certain limited works and assets due to the particular location cannot be safely separated from existing ‘live’ Transmission System;
- works and assets that are required for system protection and communication; and

¹ S.I. No. 445 of 2000: European Communities (Internal Market in Electricity) Regulations, 2000.

² Paper for Public Consultation on Contestability – February 2002, www.eirgrid.com

* For definition see section 2.1

deep reinforcement works and assets. To improve the efficiency of contestable assets provision and related communications between the TSO and applicants, the TSO undertakes to:

- appoint a Client Engineer for each new Contestable Connection;
- publish on its website a set of technical guidelines;
- publish on its website a set of guidelines that apply to route and site selection;
- provide the applicant with the project outline description at the Connection Offer issue stage; and
- provide the applicant with functional specifications and a list of relevant main equipment currently in use in the Transmission System.

All transmission assets, and regardless of the ownership of contestably-built transmission assets, shall be built to the TSO's Transmission Standard, to help ensure the safety and security of the electricity system. It is the TSO's responsibility to ensure that those contestable transmission assets built by a generator which are due to remain in the generator's ownership are built to the TSO's Transmission Standard. Connection to the network is only to be allowed on this basis and the TSO may recover from the generator any reasonable and efficiently incurred costs with respect to inspection activity necessary to ensure that this is the case. Following connection it is the generator's responsibility to ensure that it maintains to the TSO's Transmission Standards the contestable transmission assets that it built and owns. It shall be liable for any reasonable costs necessary to bring the transmission assets owned it up to the TSO's Transmission Standards, if they need to be transferred to the TAO.

In "A review of Contestability, TSO position Paper", dated January 2006, it was proposed that a bespoke design service could be offered by the TSO, at a fee, to applicants that may not have the expertise in-house to execute certain elements of the design/construction etc. However, the expressed level of interest does not appear to warrant the provision of the service at this time. Nevertheless, if interest in such a service develops then the TSO will review the situation.

1. Introduction

Contestability is the right of transmission applicants to construct all or part of their connection to the Transmission System. This right was provided under Regulation 33 of SI 445 (2000) which amended Section 34 of the Electricity Regulation Act, 1999 such that an offer made under that Section *‘may, on request of the applicant, be on the basis that the applicant constructs, or that either or both the applicant and the transmission system operator arranges to have constructed, the connection to the transmission system, and any such connection constructed or arranged to be constructed by the applicant shall be the property of the person with whom the agreement is made, and shall, for the purposes of Section 37(4), be deemed to be a direct line’*. Section 37 (4) of the Electricity Regulation Act, 1999 conveys powers to the CER to direct the owner of a direct line, or in this case a Contestable Connection deemed to be a direct line, to transfer the ownership of that Contestable Connection to the TAO, upon application of the Board, in this case EirGrid acting as TSO.

Since its introduction in 2000, contestability has been perceived as being quite a complex issue. To assist in developing common understanding the TSO, published a set of guidelines in March 2002 that underpinned the governing principles and procedures relating to contestability. Since its publication the TSO and segments of the industry have gained experience with Contestable Connections. Based on this experience and following a recent consultation with the electricity industry on the proposed amendments the TSO is of the opinion that now is an opportune time to update its March 2002 guidelines.

This revision is informed by over four years of experience with contestability and the responses from the industry during the recent consultation. This revision should further ensure that the Transmission System continues to be developed in a safe, secure, reliable and efficient manner without limiting the current scope of contestability.

This paper outlines the updated guidelines governing Contestable Connections. It includes amendments designed to ensure the Transmission System continues to be developed in a safe, secure, reliable and efficient manner without limiting the scope of contestability. The paper is structured as follows:

- section 2 presents a set of definitions, descriptions and schematics to clarify the terminology used in Contestable Connections;
- section 3 details the key level principles necessary for the successful implementation of contestability; and

- section 4 details the set of interrelated activities which constitute the process of connection to the transmission network.

The charging and associated rebate policies for Contestable Connections are not considered in this paper and are covered in the TSO's *Connection Asset Costs: Guiding Principles* document as approved by the CER.

A framework describing those circumstances when Applicant Provided Assets will be expected to be transferred to the Transmission Asset Owner (TAO) upon completion is outlined in section 4.2.8.

2. Contestable Terminology

The following definitions, descriptions and schematics clarify the terminology used solely for the purposes of this paper in describing Contestable Connections to Ireland's Transmission System.

2.1. Related Definitions

2.1.1. Applicant Provided Assets

The portion of the Contestable Assets that the applicant elects to provide shall be referred to as the Applicant Provided Assets.

2.1.2. Contestable Assets

The term Contestable Assets refers to that portion of the Shallow Connection which may be provided by the applicant, however it **excludes**:

- works and assets that are required for system protection and communication; and
- certain limited works and assets that due to the particular location cannot be safely separated from existing 'live' Transmission System.

For the provision of Contestable Assets pragmatic construction boundaries will be agreed by the TSO and the applicant cf. section 2.3.1.

2.1.3. Contestable Connection

This term refers to any connection to the Transmission System which is contestable i.e. a shallow connection where some, or all, of the required assets can be supplied and/or built by an applicant in order to connect the applicant's facility to the existing Transmission System.

2.1.4. Contestable Transmission Assets

Contestable Transmission Assets include that portion of Applicant Provided Assets that are deemed likely to form part of the Transmission System at a future date and all TSO Provided Assets.

2.1.5. Shallow Connection

The term Shallow Connection refers to assets, contestable and non-contestable, required to connect the applicant's facility to the existing Transmission System. This excludes all deep reinforcement assets.

2.1.6. Transmission Standard

The term Transmission Standard refers to that standard that applies to all Transmission System assets.

2.1.7. Transmission System

The term Transmission System refers to assets that are controlled and operated by the TSO and owned by the Transmission Asset Owner (TAO). In respect to any particular connection, it includes:

- all deep reinforcement assets; and
- Shallow Connection assets to the TAO side of the Ownership Boundary.

2.1.8. TSO Provided Assets

The term TSO Provided Assets refers to Contestable Assets that the applicant elects not to provide (and therefore the TSO arranges to provide).

2.2. Graphical Representation of Definitions

For a typical meshed connection, at a high level, the various elements as defined above can be schematically represented as shown in Figure 1 below.

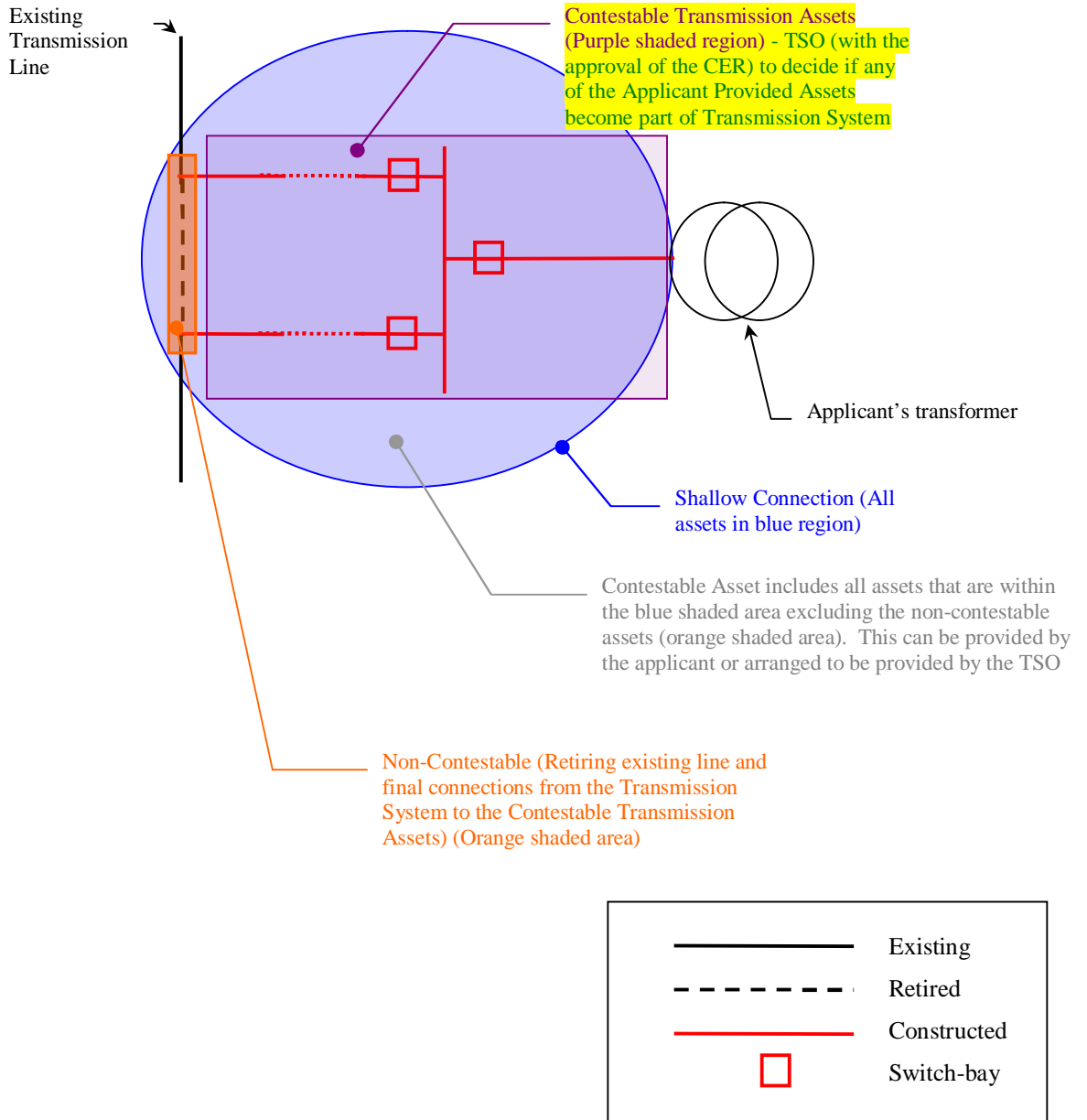

Figure 1: Schematic representation of a meshed connection outlining definitions

The relationship of the above definitions is schematically illustrated below in Figure 2, it depicts that:

- deep reinforcement assets are non-contestable and form part of the Transmission System;
- a Shallow Connection consists of Contestable Assets and non-Contestable Assets;
- the applicant can elect to provide or have the TSO arrange the provision of some or all the Contestable Assets;
- TSO Provided Assets are automatically classified as non-Contestable Transmission Assets and form part of the Transmission System; and
- Applicant Provided Assets may or may not become part of the Transmission System.

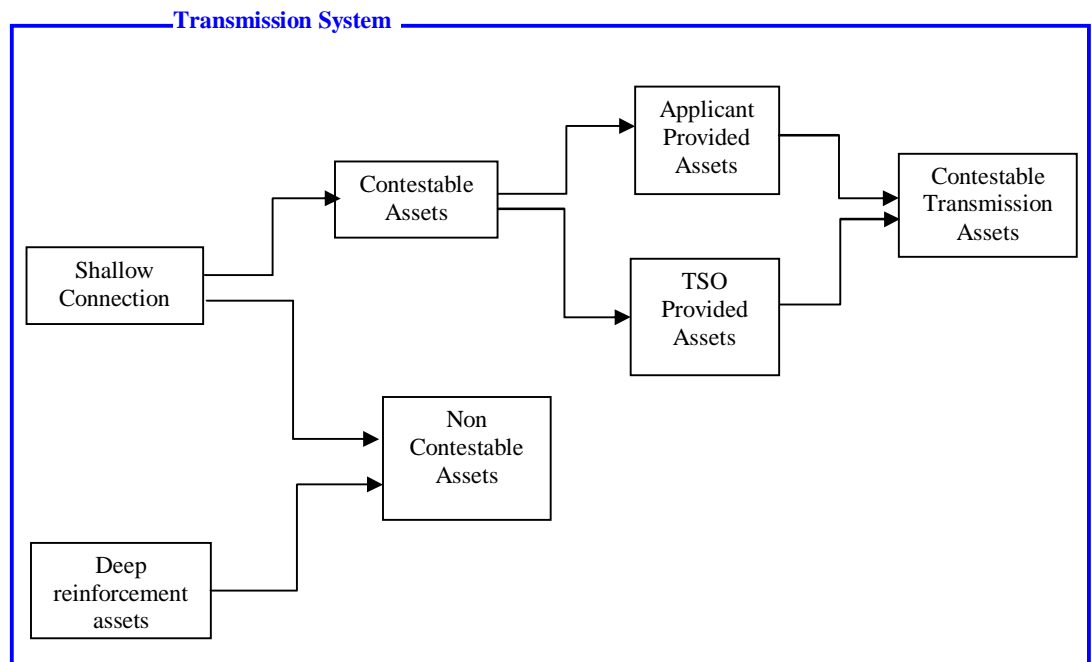

Figure 2: Schematic representation of definitions

2.3. Boundary Definitions

There are two boundary definitions that are required under a contestable regime, these are the Construction and Ownership Boundaries. These boundaries are discussed in the following sections.

2.3.1. Construction Boundary

The Construction Boundary is the location where the Applicant Provided Assets interface with the TSO Provided Assets. It is where the applicant's responsibility for providing the connection ends and the TSO's begins. In order to ensure the system security and reliability, the provision of certain assets whose construction could impact directly on the existing 'live' Transmission System can only be arranged by the TSO. Hence the Construction Boundary will be set down at a pragmatic location for each Contestable Connection. The location of the boundary is at the discretion of the applicant subject to the consent of the TSO and will be agreed prior to the TSO issuing an offer for connection to the Transmission System.

Figure 3 details some potential locations for the Construction Boundary, these are:

- Point A: the connection(s) from the existing Transmission System to new lines/cables (applicant builds all Contestable Transmission Assets to the right of point A);
- Point B: the line/cable connection from the existing Transmission System to the meshed station (applicant builds all Contestable Transmission Assets to the right of point B);
- Point C: the out-going mast of the meshed station (applicant builds all Contestable Transmission Assets to the right of point C);
- Point D: the incoming mast or cable sealing end at the overhead line/cable interface (applicant builds all Contestable Transmission Assets to the right of point D); or
- Point E: the cable sealing end into the applicant's tail station (applicant builds all Contestable Transmission Assets to the right of point E).

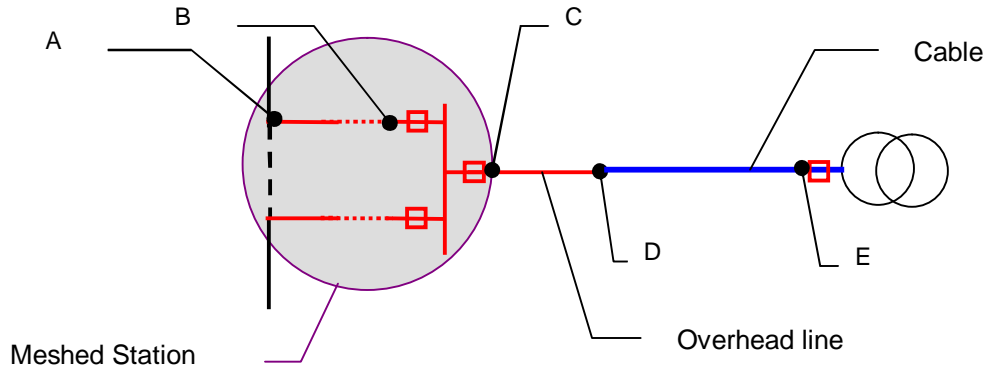

Figure 3: Potential Construction Boundary locations

2.3.2. Ownership Boundaries

The Ownership Boundary or connection point is the location where the Transmission System ends and the applicant's assets begin. The location of the Ownership Boundary is specified by the TSO in the TSO's offer for connection to the Transmission System to the applicant. For Applicant Provided Assets that are indicated in the offer to be transferred to the ownership of the TAO, this is subject to CER approval - see section 4.2.8. This is entirely separate from the Construction Boundary, as detailed above. Figure 4 details some typical Ownership Boundaries, which can be described as:

- Ownership boundary 1: a specified location at the interface between the meshed station bay and the line or cable (applicant owns and maintains all assets to the right of point 1); and
- Ownership boundary 2: the High Voltage bushings of the applicant's transformer (applicant owns all assets to the right of point 2).

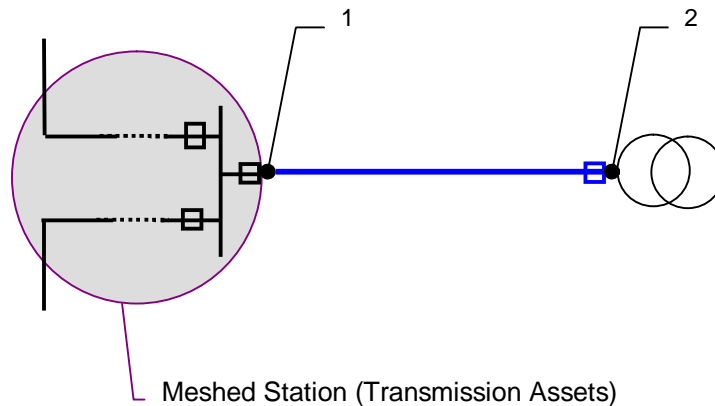

Figure 4: Typical Ownership Boundary locations

The Ownership Boundary is considered on a case by case basis, though in general it will be located at or to the right of point 1 in Figure 4 above. The implications of the location are detailed in appendix 1.

2.4. Connection Types

At a general level, connections to the Transmission System can be classified as being radial or meshed. Radial connections can be subdivided further into those serving single or multiple applicants. From the viewpoint of performance and reliability of the overall Transmission System the criticality of a connection is, in descending order:

1. Meshed connection – such as a loop-in to an existing line (figure 5).
2. Radial connection serving multiple applicants (figure 6).
3. Radial connection serving a single applicant (figure 7).

2.4.1. Meshed Connection

Meshed connections will in all cases be expected to revert to TSO operation and TAO ownership. The reliability of meshed connection assets, depicted schematically in figure 5 below, is more critical to the integrity of the system and to the continuity of supply to system users.

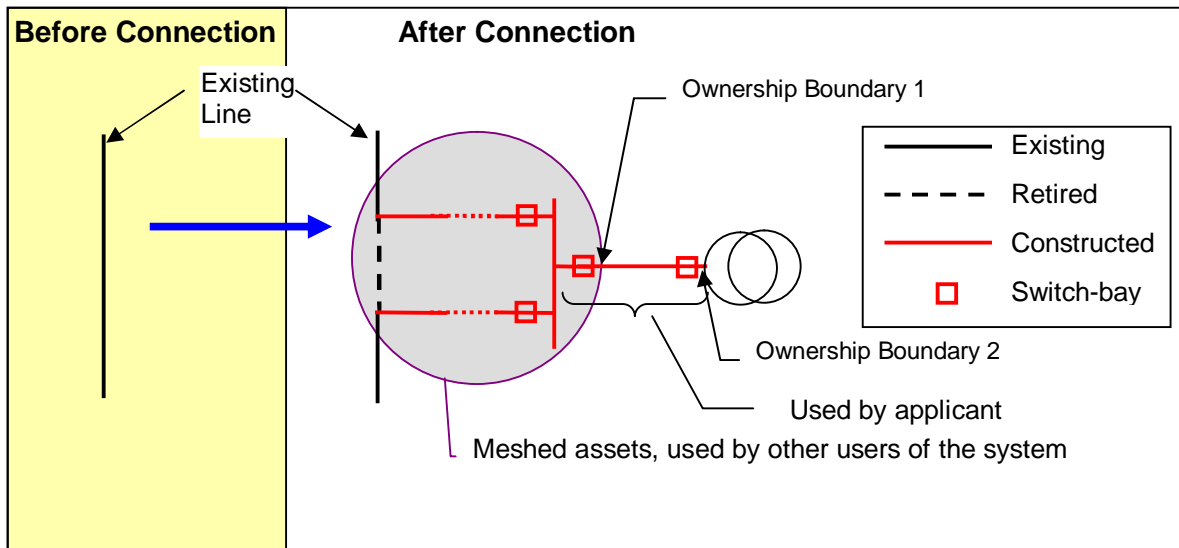

Figure 5: Graphical representation of a meshed connection

In the above figure the meshed assets will become part of the Transmission System and the radial connection (line/cable) from the meshed assets to the HV bushings of the applicant's transformer may or may not be expected to become part of the Transmission System. Hence the Ownership Boundary may be at Ownership Boundary 1 or Ownership Boundary 2 as shown in figure 5 above.

2.4.2. Radial Connection Serving Multiple Applicants

A radial connection with multiple applicants is shown schematically in figure 6. In this case the transmission station (existing) predates the new connection. The new applicants' facilities are connected to the transmission station by a series of radial circuits (overhead line or underground cable). The radial circuit (Line 1) and busbar (Busbar 1) will both form part of the Transmission System and are required to provide connections to multiple applicants. The other lines (Line 2 and 3) are not part of the Transmission System but will be built to the TSO's Transmission Standard. In this type of connection the Ownership Boundary would typically reside at the outgoing busbar disconnects on Lines 2 and 3 (Location 1) or at the HV bushing of the applicants' transformers (Locations 2 and 3) as shown in figure 6 below.

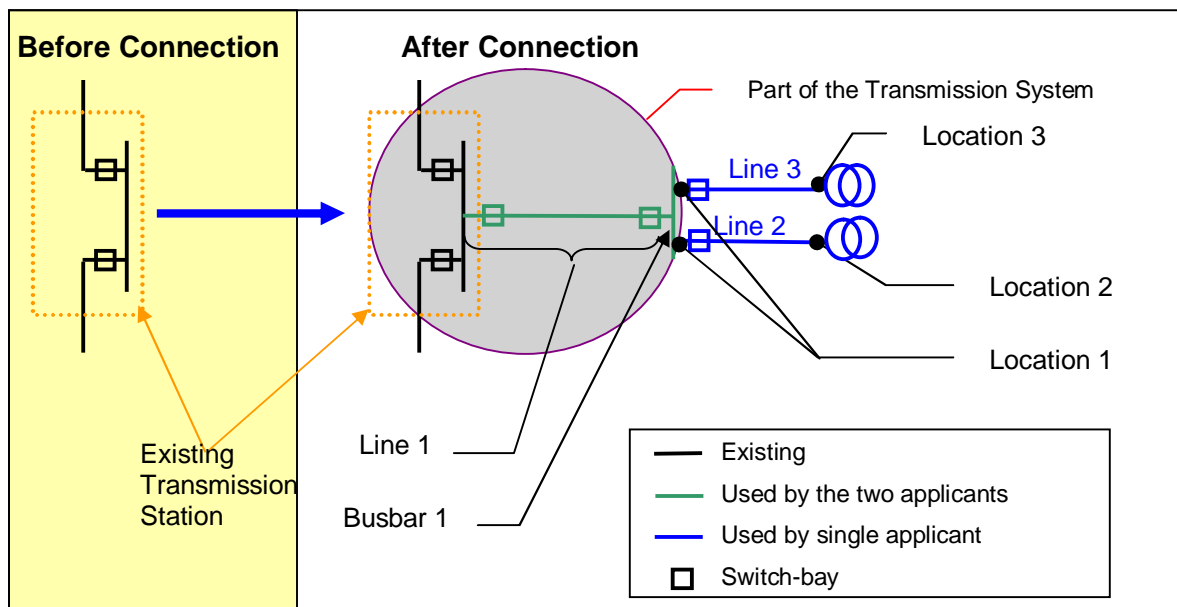

Figure 6: Graphical representation of radial connection with multiple applicants

2.4.3. Radial Connection Serving a Single Applicant

The final connection type is a radial connection for a single applicant as shown in figure 7 below. If the TSO advises the applicant that the radial connection is likely to form part of the Transmission System, then the assets will be treated as Contestable Transmission Assets.

In general all reasonable costs associated with taking over of such assets will be recovered through TUoS.

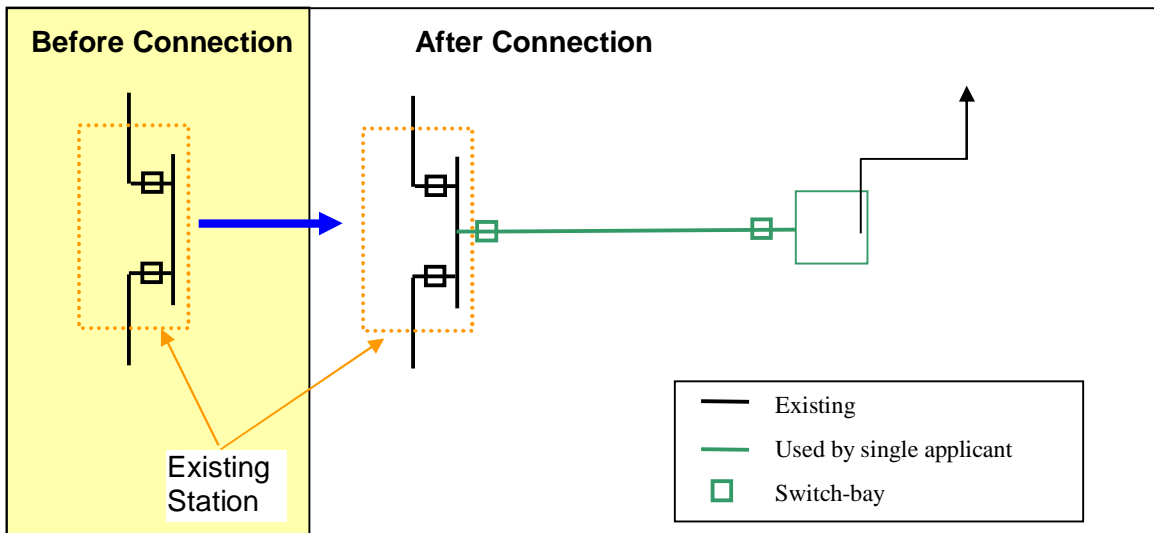

Figure 7: Graphical representation of radial connection for a single applicant

3. Key Principles

The TSO recognises the statutory right of applicants to construct their own connection assets. Hence the focus of this paper is to balance this right of applicants with the wider responsibilities of the TSO, on behalf of Transmission System users as a whole. To achieve this EirGrid has identified a number of key principles necessary for the successful implementation of contestability, these include:

- the TSO will determine the connection method consistent with the development of the Transmission System;
- the applicant elects whether or not to exercise its contestability right;
- all Shallow Connection assets have the potential to become part of the Transmission System;
- the TSO will determine the assets it expects to form part of the Transmission System and thereby the Ownership Boundary, which it will specify in the connection offer³;
- the location of the Construction Boundary is at the discretion of the applicant subject to the consent of the TSO;
- All transmission assets (shallow and deep), and regardless of the ownership of contestably-built transmission assets, shall be built to the TSO's Transmission Standards, to help ensure the safety and security of the electricity system.
- the CER has decided that the TSO shall be responsible for ensuring that those Transmission Assets built by an applicant which are due to remain in the applicant's ownership are built to the TSO's Transmission Standards;
- the TSO shall have a right to recover any reasonably and efficiently incurred inspection or other costs from the applicant associated with ensuring that all Applicant Provided Assets are built to the TSO's Transmission Standards;
- the TSO has the right to use any Shallow Connection asset for efficient development of the Transmission System and/or providing connection to other parties;
- the TSO requires the necessary degree of control over all parts of the Transmission System to meet its obligations;
- for applicants connecting at the same time and sharing Contestable Transmission Assets⁴, the Contestable Transmission Assets can be provided by one of the applicants following agreement between the applicants;

³ The final ownership boundary in respect of Applicant Provided Assets will be subject to determination by the CER in accordance with Section 37(4) of the Electricity Regulation Act, 1999

- the applicant shall own and maintain all assets on the applicant’s side of the Ownership Boundary;
- there will be one Construction Boundary for each Shallow Connection. An applicant will construct up to a given point(s) and the TSO will arrange for the connection from that point to the Transmission System; and
- all charges, contributions or rebates shall be in accordance with the applicable TSO charging policy as approved by the CER.

4. Contestability & TSO Assistance to Applicants

In the following sections we summarise the ‘Process of Connection’ and discuss the extent to which each activity in the process is contestable and the assistance that the TSO will provide for Contestable Transmission Assets. For all other situations the provision of process activities shall be considered non-contestable (i.e. TSO arranges the provision of these assets). The following sections exclude such situations.

In the consultation, it was proposed that a bespoke design service to connecting parties could be offered by the TSO, at a fee, to applicants that may not have the expertise in-house to execute certain elements of the design/construction. However, the expressed level of interest did not warrant the provision of the service. Nevertheless, if interest in such a service develops then the TSO will review the situation.

4.1. Process of Connection

The process of connection to the Transmission System can be considered as a number of closely interrelated activities, which is initiated by a prospective party submitting an application for connection to the TSO, setting out the location of the intended connection and other relevant details of the proposed facility. Following acknowledgment of a complete application by the TSO, the major activities that follow typically include:

- the TSO determines the connection method and provides the connecting party with the contestability options relating to that connection in accordance with the Offer Process⁵;

⁴ Shared assets are that portion of the shallow connection that is required for connection by more than one connecting party. These assets are shared between the connecting parties

⁵ Offer Process is the TSO process for issuing transmission connection offer to connecting parties. The Offer Process is approved by the CER and is available on the TSO’s website

- the applicant chooses whether or not to pursue a contestable option and the connection agreement is executed;
- the TSO provides the outline design and functional specification;
- the connection to the Transmission System is provided. The provision of a connection to the Transmission System includes the following activities:
 - route and site selection;
 - attaining planning consents;
 - detailed design, procurement and construction;
 - commissioning & first energisation; and
 - ownership transfer of assets; and
- assets are operated and maintained in accordance with Grid Code requirements.

Although there is a broadly sequential order to the above set of steps, in practice there will be some iteration and overlap. For example, issues raised in the planning process may necessitate a review of the route selection.

4.2. Contestable Transmission Assets

4.2.1. Connection Method

Given the TSO's responsibility for the overall development of the Transmission System, it shall have the final decision on the connection method i.e. the type of connection from the existing Transmission System to the HV bushings of the applicant's transformer(s). This includes specification of the voltage level the connection is made at, the type of connection (radial or meshed) and the connection point.

The final determination of the connection method lies with the TSO, as such the determination of connection method is non-contestable. Assets built by an applicant, irrespective of ownership, shall be built to the TSO's Transmission Standards.

4.2.2. Applicant Choice & execution of the connection agreement

The applicant chooses whether or not to provide the Contestable Assets and the connection agreement is executed.

4.2.3. *Outline design and functional specification*

The TSO is responsible for the security, safety, reliability and efficient operation of the system. Therefore, the TSO must have adequate controls in relation to the engineering design standards, the quality of materials used, standard lifetime of assets, the methods for construction and the procedures for commissioning of plant connecting to the Transmission System. Hence the TSO shall specify the outline design and functional specification of the connection.

To assist the applicant in the subsequent activities the TSO will:

- publish a set of technical guidelines that apply to engineering design (including safety standards);
- provide the applicant with functional specifications following connection agreement execution. This shall include a more detailed scope of work, an outline design including the single line diagram and site layout requirements, the functional requirements of the equipment and the interface details; and
- provide a list of relevant main equipment currently in use on the Transmission System (with the cooperation of the TAO). This will allow the applicant to take into consideration this list when choosing the connection equipment for Contestable Transmission Assets. The applicant does not have to select equipment from this list, however if the applicant opts not to select equipment from this list then the applicant may have to provide additional equipment as spares and provide for training on this equipment.

The applicant will be responsible for ensuring that the connection meets the functional requirements as specified by the TSO.

4.2.4. *Route and Site Selection*

The TSO and the applicant shall pursue a collaborative approach to route selection, with the TSO having the right to determine the final route. The reason for the TSO having the final decision on route selection is that it is vitally important that any new transmission assets contribute effectively to the evolution of the overall Transmission System. Similarly site selection must meet the TSO requirements.

To ensure all applicants are treated in the same manner the TSO will publish a set of guidelines that apply to route and site selection.

4.2.5. *Planning Consents*

In general, an applicant will be responsible for submitting a request for planning permission, but only after prior agreement on the possible routes and sites with the TSO. The TSO will support the applicant in its application where it is reasonably required. The Contestable Transmission Assets may also be required by the TSO in conjunction with other development plans or may be in an area where the TSO is separately developing infrastructure. Therefore, in certain circumstances, the TSO retains the right to prepare and submit the planning permission application. However, this is expected to be the exception.

4.2.6. *Detailed Design, Procurement and Construction*

The detailed design of Contestable Transmission Assets is contestable subject to TSO outline design and functional specifications. The detailed design shall be submitted to the TSO for review and acceptance, as the TSO may be responsible for the operation and maintenance of these assets. The TSO has the right to specify test requirements and standards on materials for Contestable Transmission Assets. The TSO also has the right to specify requirements to provide spares and minimum warranty periods, to the extent that plant maintenance and availability could be affected. The TSO may also reserve the right to insist on operational and maintenance training for TSO/TAO staff by the equipment supplier.

Construction and procurement of Contestable Transmission Assets is contestable, subject to TSO outline design and functional specifications. However, the TSO will have unrestricted⁶ rights of inspection with respect to Contestable Transmission Assets under construction. The TSO will carry out inspections to ensure that the detailed designs, plant, materials and works, including scheduling, meet the requirements of the TSO's functional specifications, outline designs, generic standards and detailed designs.

⁶ subject to health & safety requirements and access protocols

The TSO shall appoint a Client Engineer⁷ for each connection where the applicant is providing Contestable Assets. The costs of the Client Engineer shall be the responsibility of the connecting party in accordance with any general principles concerning the bearing of costs which are approved by the CER and which may be amended from time to time.

4.2.7. Commissioning & first energisation

Commissioning consists of pre-commissioning and commissioning tests. The commissioning shall always be a collaborative exercise between the connection party and the TSO. The TSO has the right to specify pre-commissioning tests to be carried out by the applicant prior to first energisation. The first energisation and the commissioning tests are arranged by the TSO. Prior to first energisation the applicant must give written "proof of readiness" to the TSO. The TSO controls the timing of any network outages necessary to enable a safe and secure completion of the Contestable Transmission Assets to the existing Transmission System.

4.2.8. Ownership transfer of Assets

Applicant Provided Assets may be transferred to the TAO upon completion of commissioning. In the event that this is the case, the TSO will seek the CER's approval under section 37 of the Electricity Regulation Act, 1999, to have the assets transferred to the TAO. If the CER approves the transfer, the Applicant Provided Assets will then

⁷ The typical role of the Client Engineer includes, but is not limited to:

- § reviewing the connecting party's detailed designs;
- § monitoring progress of the Contestable Connection against agreed timelines;
- § appraising changes proposed by the connecting party and approving, or otherwise, consequential changes to the outline design, generic design standards and functional specifications and reviewing consequential changes to the connecting party's detailed designs;
- § appraising and approving changes proposed by the connecting party to the project implementation plan, the connecting party's detailed designs and/or the construction works consequent upon any changes made by the TSO to the committed project parameters;
- § ensuring that the Transmission System requirements are met in order for the commissioning tests to proceed; and
- § witnessing commissioning tests to ensure commissioning procedures and energisation procedures are adhered to.

The Client Engineer will have unrestricted (subject to health & safety requirements and access protocols) rights of inspection with respect to all Contestable Transmission Assets under construction. The Client Engineer will carry out inspections to ensure that the detailed designs, plant, materials and works, including scheduling, meet the requirements of the TSO's functional specifications, outline designs, the generic standards, and the detailed designs

transfer to the TAO for a nominal fee (e.g. 1 Euro)⁸. The TSO has developed a framework outlining those circumstances where it would ordinarily seek CER direction for the transfer of Applicant Provided Assets to the TAO. This is:

- a) Where the assets are, or are likely to be in the future, shared by more than one party (either by system users or other parties connecting to the system); or
- b) Where it is deemed appropriate, either at the time of connection or in the future, that the assets be utilised to connect another party; or
- c) Where such assets are specified to a higher standard than would otherwise be required, with the aim of connecting further users or as part of overall system development. In such instances, the TUoS customer will have contributed to the cost of the assets; or
- d) Where it is deemed appropriate that the assets may be utilised as part of wider system development; or
- e) Where another party or general system users might materially be affected by the performance of the assets in question, including where the ownership and maintenance of the assets is important for system security or protection of the integrity of the system.

The TSO also requires wayleaves and/or easements on land to entitle access to Contestable Transmission Assets at all times for the purposes of maintenance, inspection and surveying. These rights must be obtained by the applicant, at the applicant's own cost, and assigned to the TAO and the TSO, when ownership is transferred to the TAO.

4.2.9. Operations & Maintenance

Following connection it is the generator's responsibility to ensure that it maintains to the TSO's Transmission Standards the contestable transmission assets that it built (i.e. Applicant Provided Assets) and owns. It shall be liable for any reasonable costs necessary to bring the transmission assets owned it up to the TSO's Transmission Standards.

⁸ The cost of transfer shall take into account the applicable charging policy had the assets been TSO provided and any deviation in the build specification by the TSO from that which the applicant is liable to be charged for in accordance with the connection charging principles pertaining at the time

Operational control shall rest with the TSO to ensure system security and safety. Maintenance of Contestable Transmission Assets is not contestable once Contestable Transmission Assets are transferred to the TAO. Maintenance for these assets will be arranged by the TSO in accordance with normal procedures.

5. Conclusions

The following points summarise the key principles underpinning the contestability regime:

- (a) All Transmission Assets shall be built to the TSO's Transmission Standards.
- (b) The TSO shall be responsible for ensuring that Transmission Assets built by an applicant which are due to remain in the applicant's ownership are built to the TSO's Transmission Standards. Any reasonable and efficiently incurred costs associated with this inspection or assurance will be borne by the applicant.
- (c) The following connection elements are non-contestable:
 - deep reinforcements;
 - connection method determination;
 - works and assets that are required for system protection and communication;
 - certain limited works and assets that cannot be safely separated from existing 'live' system;
 - determination of the Ownership Boundary;
 - operational control;
 - outline specification;
 - functional specification of Contestable Transmission Assets;
 - commissioning of Contestable Transmission Assets; and
 - maintenance of Contestable Transmission Assets.
- (d) The following elements are contestable but require TSO review and/or acceptance for Contestable Transmission Assets:
 - detailed design;
 - route and site selection;
 - planning permission;
 - wayleaves;
 - equipment procurement; and
 - construction.

- (e) The TSO will appoint a Client Engineer for each new Contestable Connection.
- (f) To inform the decision making of potential applicants and to assist the provision of Contestable Connections, the TSO will:
- publish on its website a set of technical guidelines to assist a applicant when contemplating a Contestable Connection. These will include generic design standards for the standard connection types and the arrangements for the design approval process;
 - will publish a set of guidelines that apply to route and site selection;
 - provide the applicant with the project outline description at the Connection Offer issue stage. The project outline description will include the Ownership and Construction Boundaries, a timeline for provision of the project specific functional specifications and arrangements for project management of the design and approval process; and
 - provide the applicant with functional specifications following acceptance by the applicant of the TSO Offer for connection to the Transmission System. This shall include a more detailed scope of work, an outline design including the single line diagram and site layout requirements, the functional requirements of the equipment, the interface details, and (with the cooperation of the TAO) a list of relevant main equipment currently in use on the Transmission System.

Appendix 1: Ownership Boundary

The implications of the location of the Ownership Boundary are as follows:

- The TSO's Transmission Standard applies to all Contestable Transmission Assets
- The Client Engineer's role extends to cover all Contestable Transmission Assets on the Transmission System side of the Ownership Boundary independent of who constructs these assets;
- TAO carries out the maintenance and repair work to all assets on the Transmission System side of the Ownership Boundary;
- The applicant is responsible for maintaining, repairing and if appropriate decommissioning all assets on the applicant's side of the Ownership Boundary;
- The applicant pays the costs of maintaining the Shallow Connection assets constructed to connect the applicant's facility to the Transmission System. This payment is referred to as the 'On Going Service Charge' (OGSC);
- Subject to the then current market rules and current TSO pricing policy as approved by CER the applicant may receive constraint payments from the TSO if they have firm financial access to the Transmission System and if the assets on the Transmission System side of the Ownership Boundary are unavailable;
- If applicable, the TSO arranges the decommissioning of all dedicated shallow assets on the Transmission System side of the Ownership Boundary upon termination of the connection agreement;
- The applicant is liable for the cost of decommissioning all dedicated shallow assets on the Transmission System side of the Ownership Boundary upon termination of the connection agreement;
- Following connection it is the generator's responsibility to ensure that it maintains contestably-built transmission assets owned by it to the TSO's Transmission Standard. It shall be liable for any reasonable costs necessary to bring the transmission assets owned by it up to the TSO's Transmission Standard.
- Where, upon receipt of an application by the TSO, the CER has directed Applicant Provided Assets be transferred to the TAO, prior to the TAO assuming ownership, the TAO has the right to perform due diligence on assets constructed by the applicant which are intended to form part of the Transmission System; and
- In general, for non-generation applicants the Ownership Boundary will be at the HV bushings of the applicant's transformer(s).