



EIRGRID

EirGrid Customer Forum

Monday 27th September 2010

AGENDA

- 2.00pm **Opening Remarks** – *Claire Kane*
- 2.10pm **Welcome and Overview** – *Andrew Cooke*
- 2:20pm **Grid25 High Level Update** – *Aidan Corcoran*
- 2:30pm **How the ITC Program, Constraints studies, Connection Studies & Network Development planning fit together** – *Simon Grimes*
- 2:40pm **Constraints Modelling and Reporting** – *Eoin Kennedy*
- 3:00pm **Optimising Network Development** – *Louis Fisher*
- 3:20pm **Roadmap for Future Work** – *Simon Grimes*
- 3:40pm **Tea/coffee break**
- 4:00pm **Questions** *fielded by Claire Kane*
- 4:45pm **Closing Remarks** – *Derek Lawler*



EirGrid Customer Forum

Aidan Corcoran, Grid25 Programme Manager
27th September 2010



Grid Development Strategy - Grid25



GRID25

A Strategy for the
Development of Ireland's
Electricity Grid for
a Sustainable and
Competitive Future

2,200 km Upgrades

1,150 km New Build

€4 billion

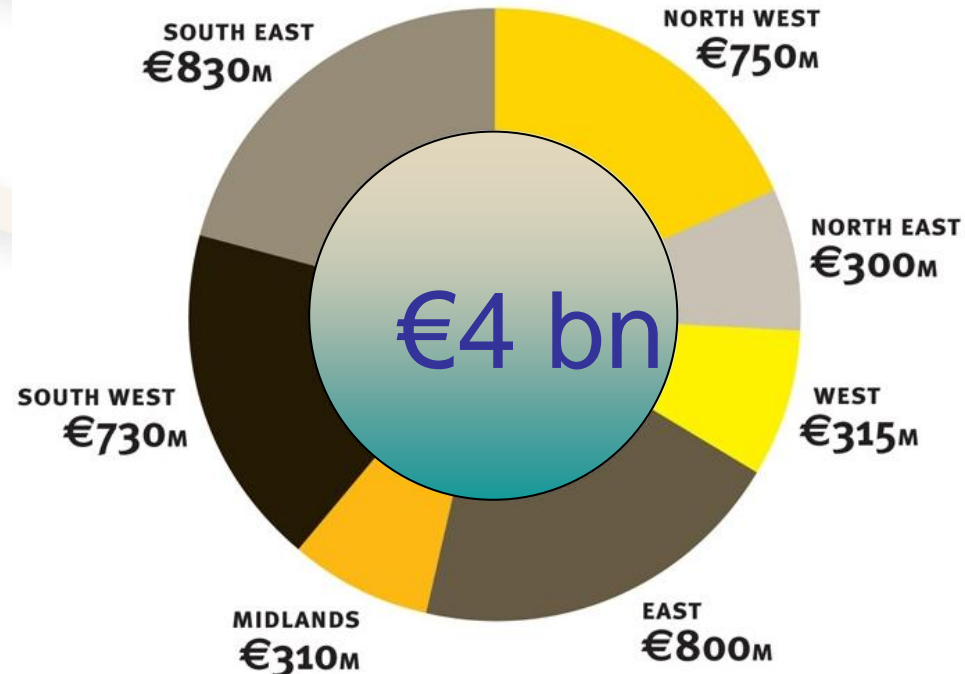

Grid 25 Programme

- Drivers
- Grid25/Challenge
- Implementation and Work Streams
 - Reorganisation
 - Planning/Environmental Policy
 - Stakeholder/Strategic Consultation
 - Ongoing Projects
 - Major New Regional Projects



EirGrid Organisational Change

- Programme Management Office
 - Coordinate the delivery of the Grid 25 Programme
 - Monitoring and reporting
 - Specialist support and training
 - Stakeholder Interaction
- Three Regional Groups



Planning Environmental Policy

- Strategic Infrastructure Act
- Regional Planning Guidelines
- County Development Plans
- Habitats Guidelines
- Strategic Environmental Assessment
- An Bord Pleanála

Stakeholder/Public Engagement

- National Forum
 - Dublin – May 24th
- Regional Forums
 - Killarney – July 23rd
 - Waterford – October 15th
 - Carlow – October 29th
 - Castlebar – November 12th
- Project Open Days (July – October 2010)
 - Millstreet, Macroom, Tarbert
 - Portlaoise, Kilkenny, Listowel



Strategy Prior to Public Consultation on a scheme

- Continue to Build Awareness
- Continue strategic input to Policy
- Complete SEA Process
- National Stakeholder Forum
 - Develop National/EirGrid Policy Guidelines
- Regional Stakeholder Forum
- Regional Consultation
- Commence Consultation of Schemes



Transmission Projects included in PR3



	400 kV / 220 kV/ 110 kV
No. of New Stations	13
Circuit length	1300 km
No. of New Transformers	30
No. of New Capacitor Banks	14
Uprates	1900 km

Transmission Projects in Progress

	400 kV / 220 kV/ 110 kV
No. of New Stations	16
Circuit	640 km
No. of New Transformers	17
No. of New Capacitor Banks	12
Uprates	665 km

GRID25

- Stakeholder Awareness Campaign
- Major Schemes – Ongoing Analysis
- Projects under construction
 - 400/220/110kV Circuits
 - 400/220kV substation developments
 - 220/110kV circuit upgrading
 - Capacitor Banks

**How firm access calculations,
constraint studies, network planning
& infrastructure roll-out
fit together**

Simon Grimes

Manager Transmission Access Planning

27 September 2010



GOVERNMENT & EUROPEAN POLICIES / ECONOMIC INFLUENCES

GRID DEVELOPMENT STRATEGY (GRID25)

**Proposed
Network
Models**

**ITC
Program**

**Deep
Reinforcement
Studies**

**Constraint
Studies**

**Network
Planning
Optimisation**

**Network
Build
Programme**

**Scheduled
FAQs**

**Associated
Deep
Reinforcements**

**Forecast
Constraints**

**Transmission
Development
Plan**

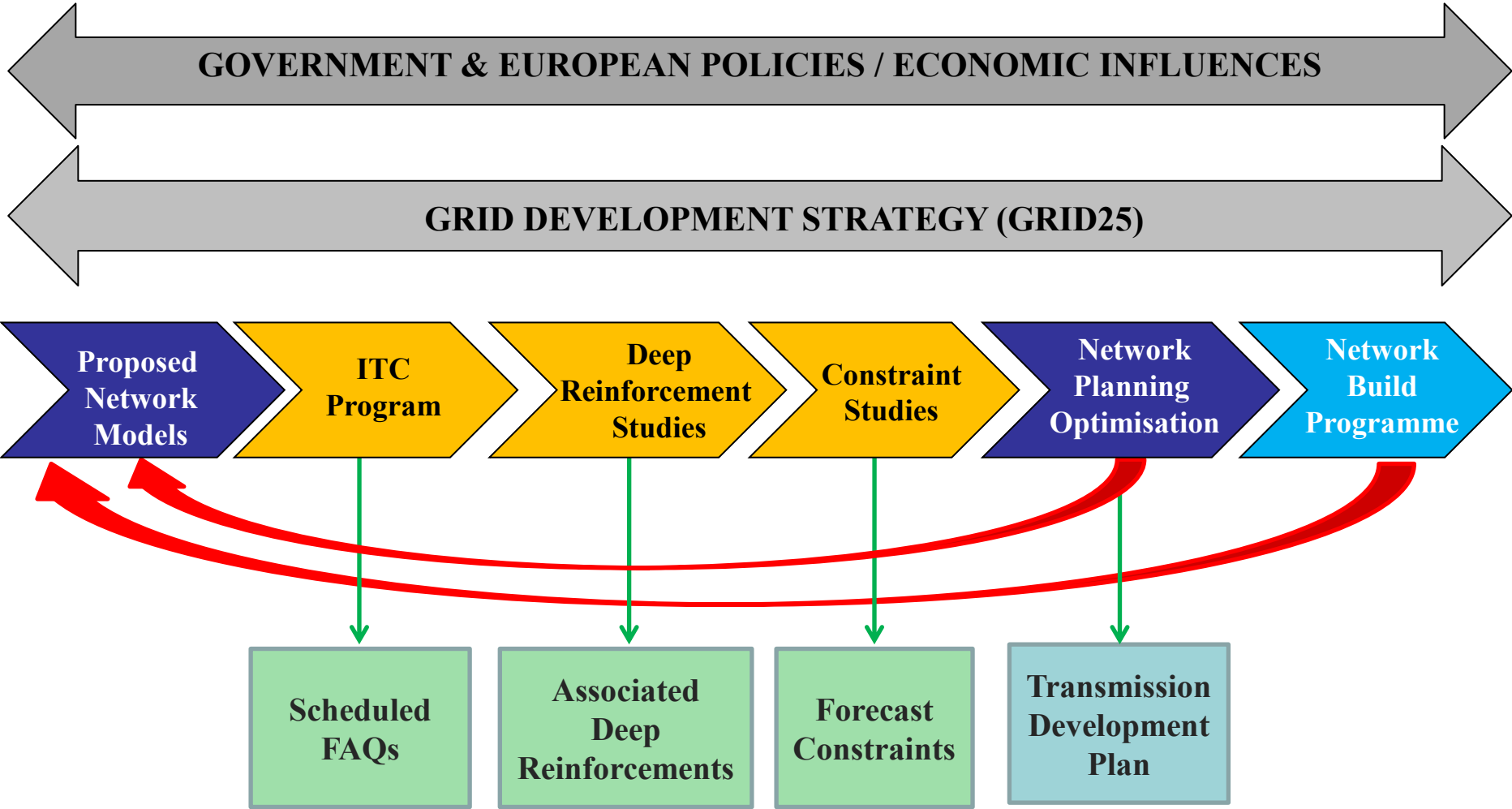

**How firm access calculations,
constraint studies, network planning
& infrastructure roll-out
fit together**

Simon Grimes

Manager Transmission Access Planning

27 September 2010



GOVERNMENT & EUROPEAN POLICIES / ECONOMIC INFLUENCES

GRID DEVELOPMENT STRATEGY (GRID25)

**Proposed
Network
Models**

**ITC
Program**

**Deep
Reinforcement
Studies**

**Constraint
Studies**

**Network
Planning
Optimisation**

**Network
Build
Programme**

**Scheduled
FAQs**

**Associated
Deep
Reinforcements**

**Forecast
Constraints**

**Transmission
Development
Plan**

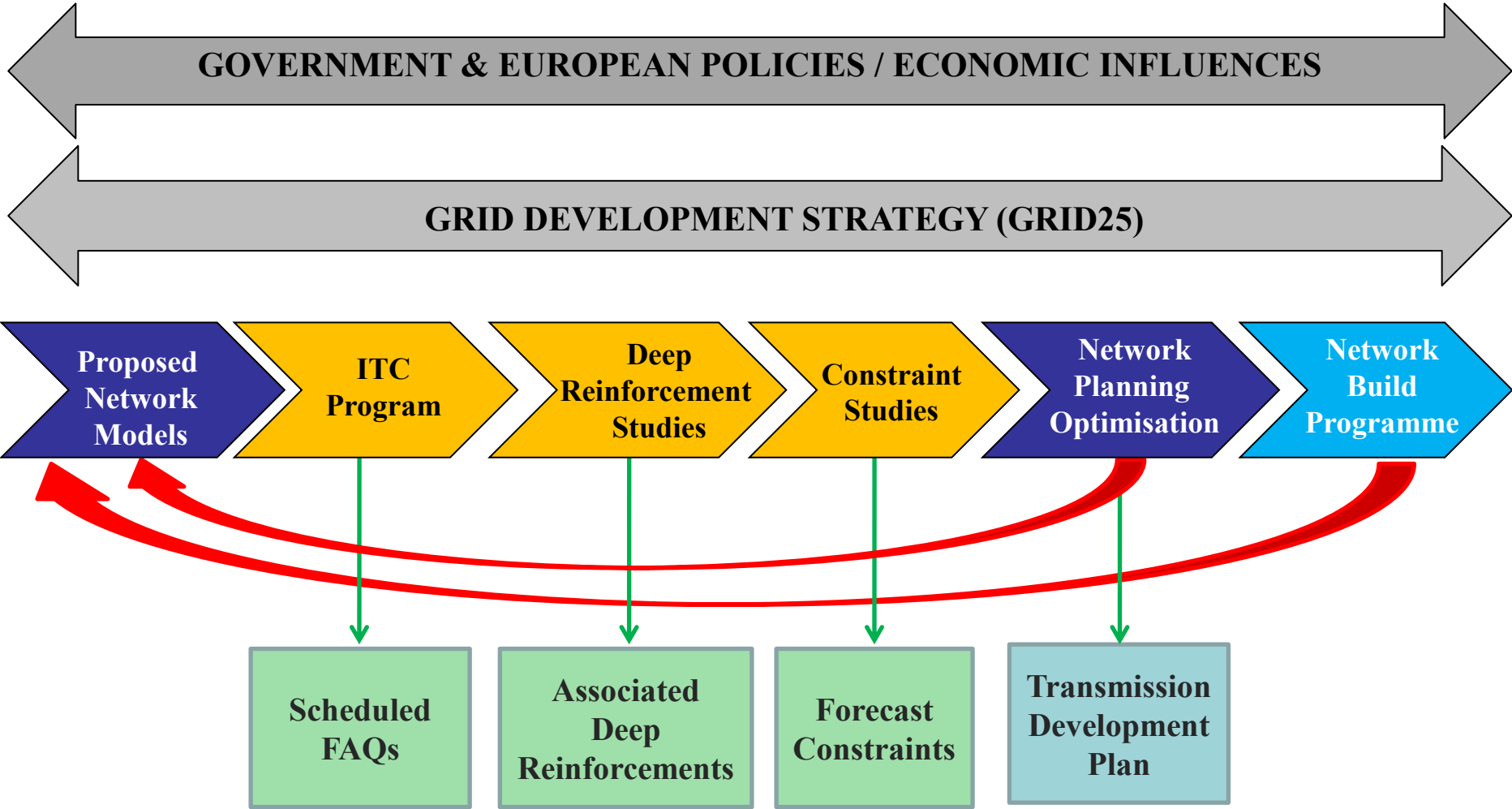

Constraints Modelling and Reporting

Presentation to EirGrid Customer Forum

27th September 2010

Eoin Kennedy
Generation Analysis, EirGrid



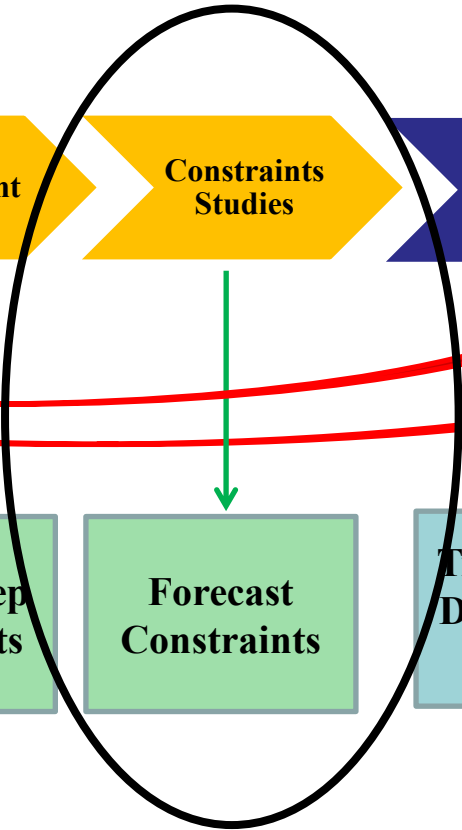
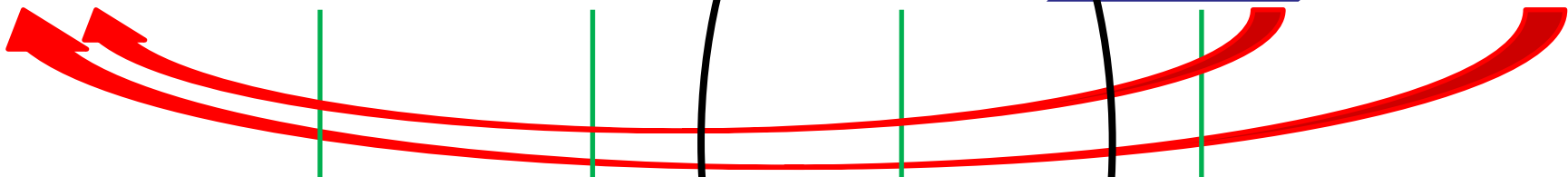
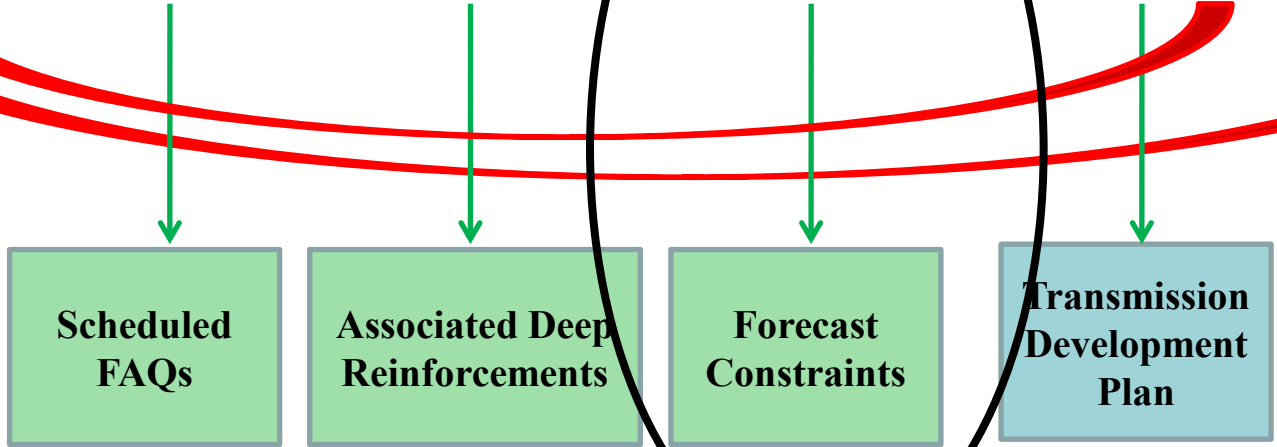

Overview of Presentation

- Introduction
- Overview of constraints modelling
- Presentation of high-level results for the period 2011 - 2022.
 - Wind Curtailment/Constraint results
 - 2020 RES-E results
- Future plans
- Summary



Gate 3 Direction & Constraints

- The CER Gate 3 direction CER/08/260 instructed EirGrid to:
“issue estimates, generally with the offers, of the likely incidence of constraining off of the recipients' generation output from the date of commissioning of the generator until all necessary transmission reinforcement works are expected to be completed”.
- In addition to transmission constraint estimates, EirGrid have also calculated estimated curtailment levels.
- ‘Physical’ curtailment and transmission constraint levels determined.
- We are not determining who would be financially compensated for curtailment/constraint.
 - The market rules are currently subject to consultation following the recently published draft decision paper on ‘*The Principles of Dispatch...*’.



Curtailement and Constraint



Curtailement and Constraint

- For the purposes of constraints modelling/reporting, the terms Curtailement and Constraint are used to refer to changes in generator output under different specific circumstances.

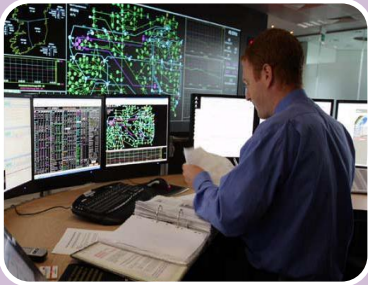

Curtailement

- Changes to generator output from the most economic dispatch in order to ensure that sufficient quantities of the system services necessary to run a safe and secure electricity system are available.
- At very high wind generation levels, further reduction of wind generator output may be required if wind generation levels still exceed demand.



Constraint

- Changes to generator output from the most economic dispatch due to transmission network limitations, specifically the overloading of transmission lines, cables and transformers.
- Constraint is location-specific and can be reduced by transmission network reinforcements.

Draft Dispatch Rules

- The CER provided a draft dispatch rule-set to employ in the modelling.
- Draft dispatch rule-set is consistent with the recently published proposed position paper on '*The Principles of Dispatch...*'.
 - There is still a possibility that the dispatch principles will change when the final decision paper is published.
- Because of the draft dispatch rule-set, CER instructed EirGrid not to issue the Area K constraints estimate report or subsequent Area reports as they became ready.
- CER recently decided that EirGrid may issue an interim report called 'Possible Generator Output Reductions' (PGOR) to Gate 3 applicants who request it.



Description of Constraints Modelling

Inputs

- Demand shape
- Generator characteristics
- Wind Profiles
- Fuel prices
- Operational Rules
- Transmission network

PROMOD

- Chronological Unit Commitment Economic Dispatch model
- 8760 hours modelled per year
- Minimise the system cost (fuel bill/operating costs) subject to constraints such as spinning reserve, generator capabilities, transmission network limitations etc.

Outputs

- Hourly generation pattern for each generator (No. of start-ups, loading patterns etc.)
- System/Fuel cost
- Fuel consumption by fuel type
- Emission quantities
- Transmission line loadings

Draft Operational Rule-set

- A draft operational rule-set, informed by the results from the Facilitation of Renewables workstream, was used. The rule-set covers:
 - Minimum conventional generation requirements, operating reserve requirements and North-South Interconnection power flows
 - Limits on the instantaneous wind penetration
 - Transitions T1 – T4 in the graph below require certain pre-conditions to be satisfied.

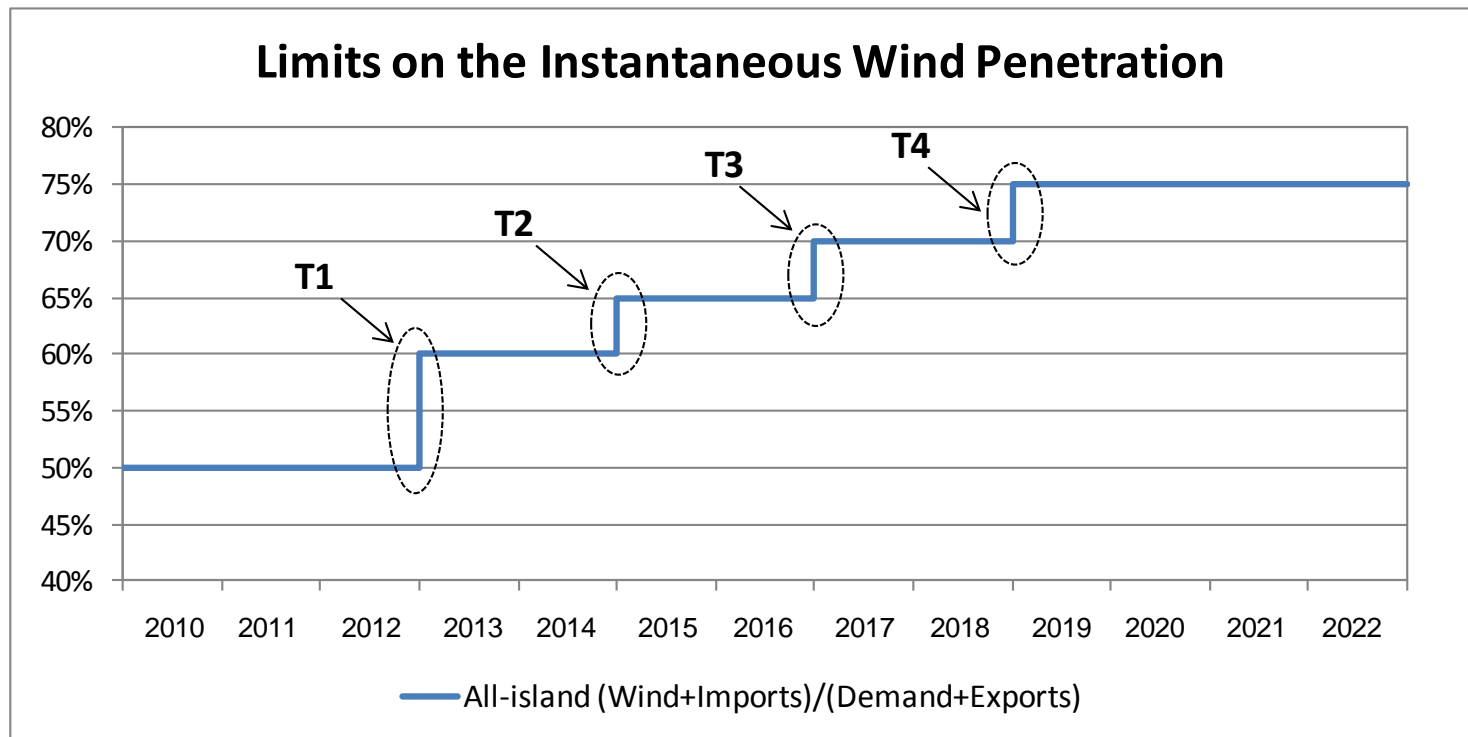

Curtailment/Constraint Determination

- Where possible, curtailment is spread proportionally.
- However, the optimisation will curtail wind generator output in congested areas ahead of wind generators in non-congested areas.
- There are times when generation reduction at a node can be due to both curtailment and constraint. In this case, the methodology allocates reductions to curtailment.

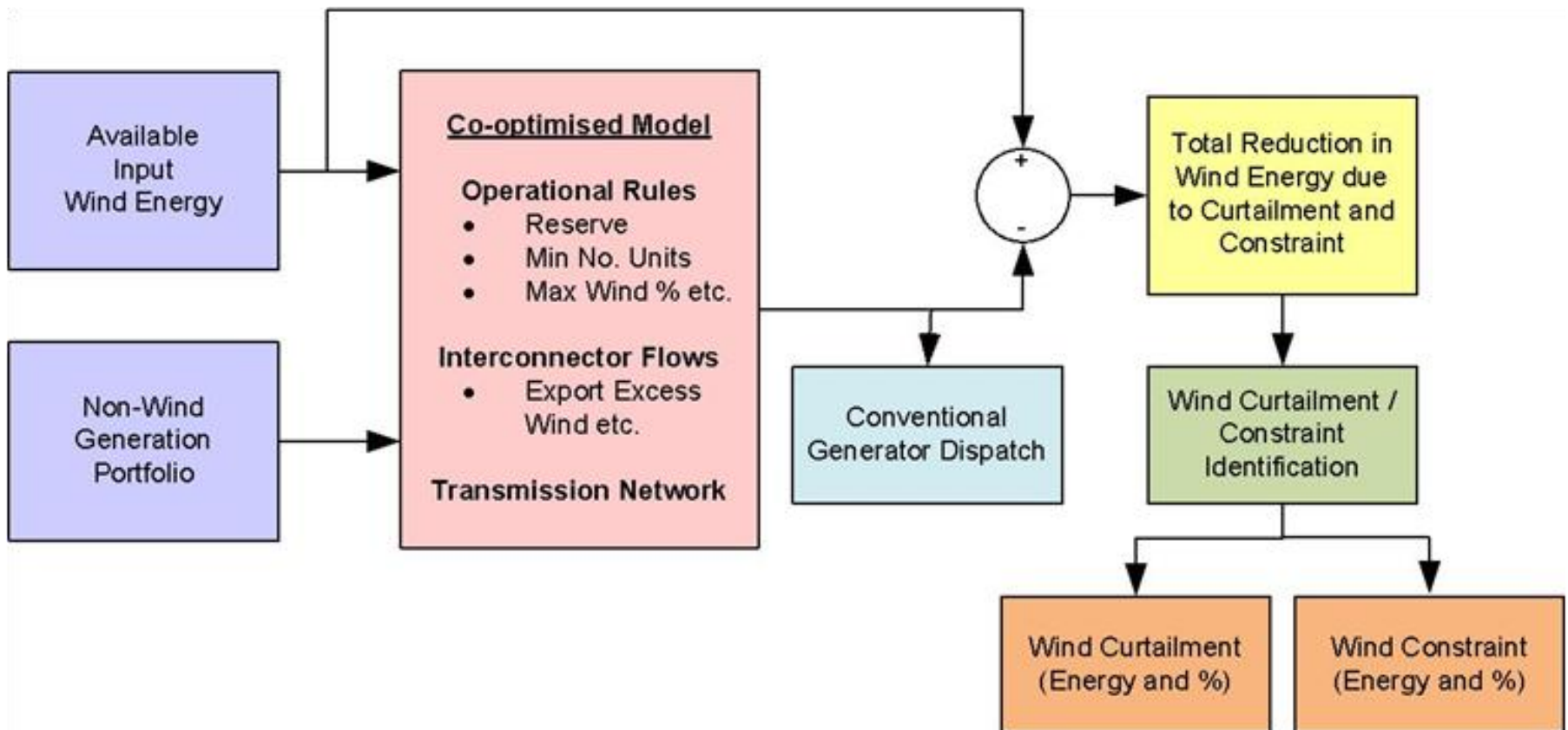

Scenarios

- Four scenarios were examined for each study year for the period 2011 through 2022.

Scenario	Gate 3 Wind (33%,66%,100%)	Fuel Price (Base Case, Alternative)
Scenario 1 (SN1)	100%	Base Case
Scenario 2 (SN2)	66%	Base Case
Scenario 3 (SN3)	33%	Base Case
Scenario 4 (SN4)	100%	Alternative



Installed Wind Capacity

- All IE generation added based on an estimate of shallow connection leadtimes

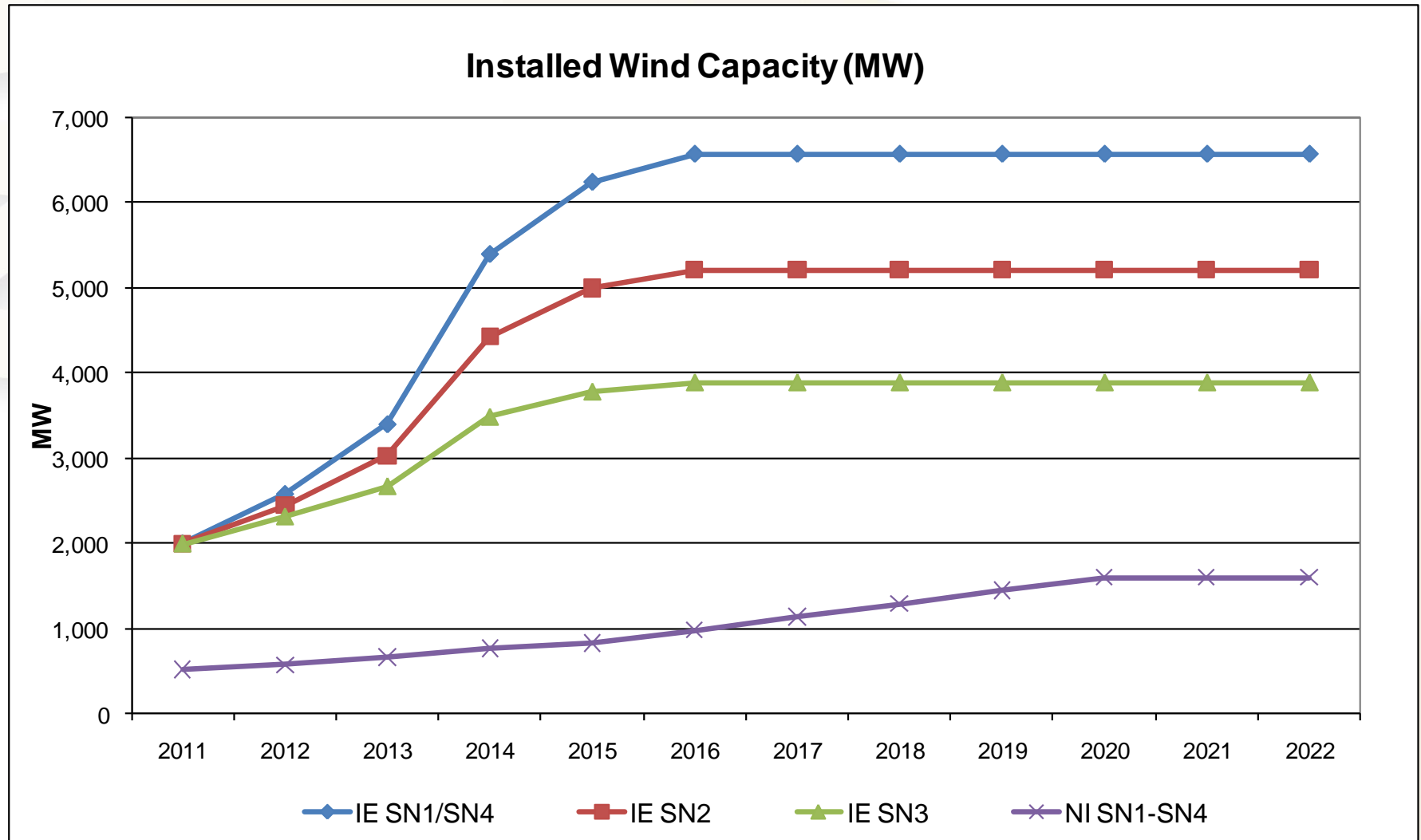

PGOR System Wind Curtailment Results

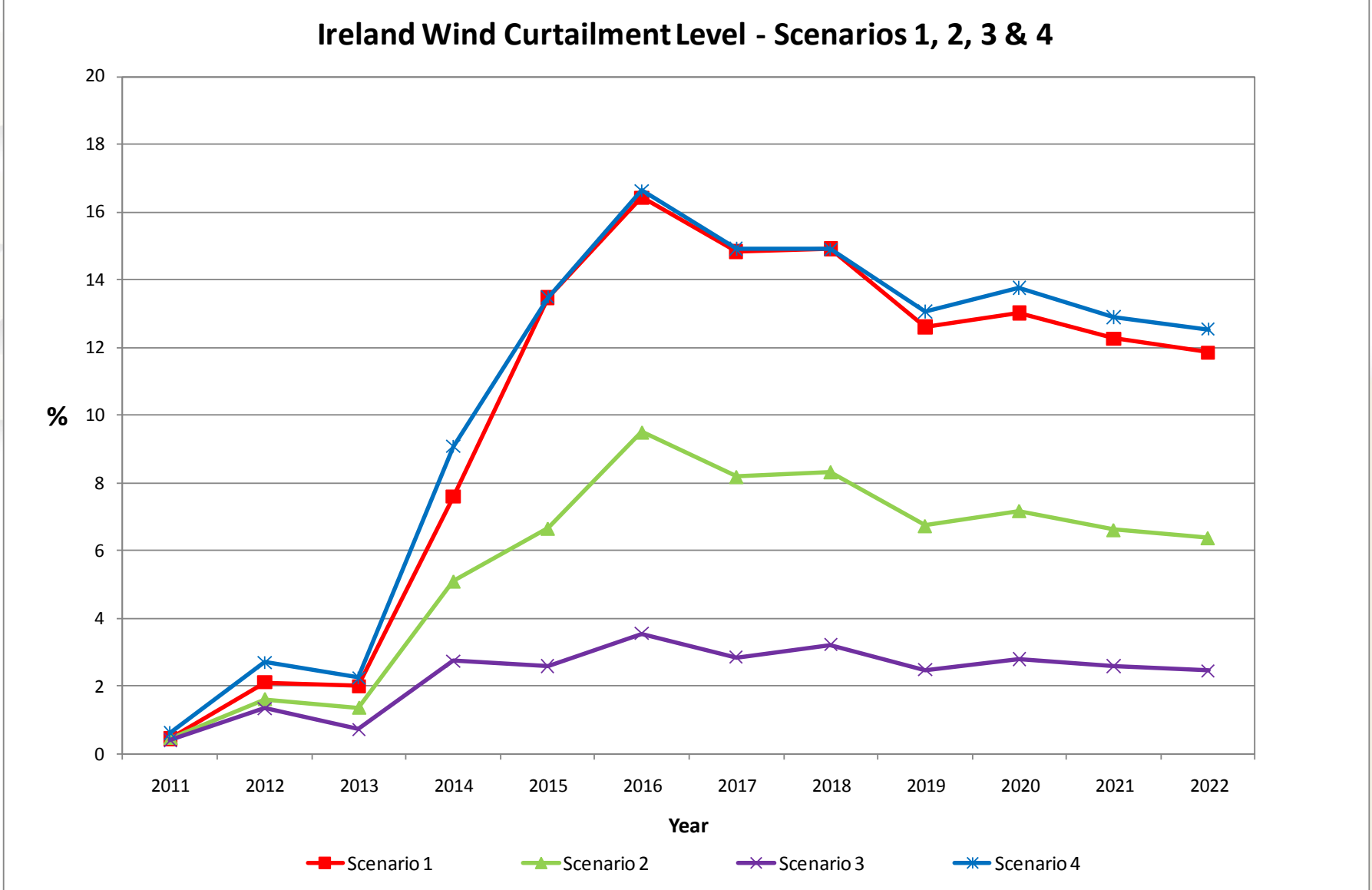

PGOR System Wind Constraint Results

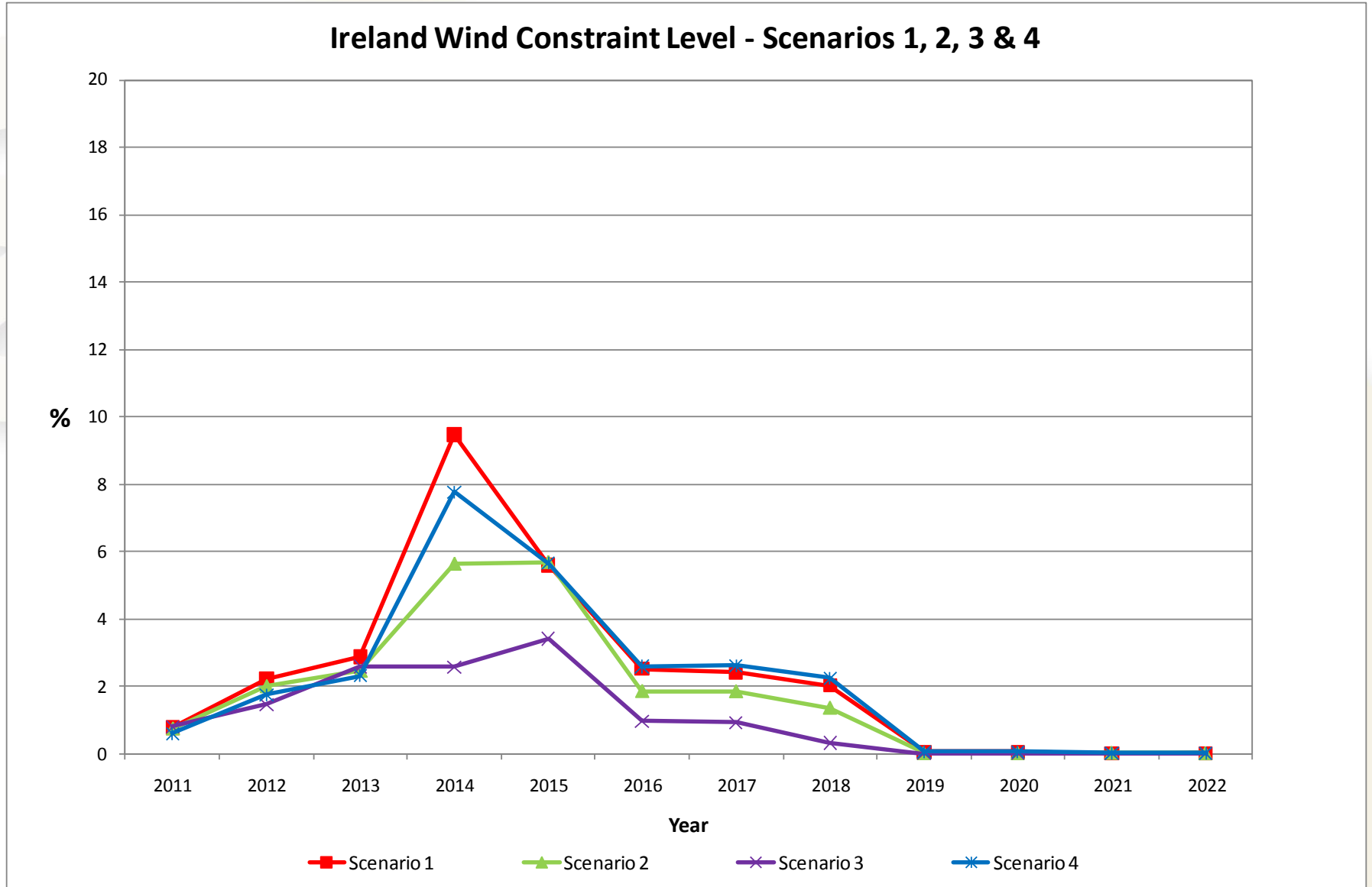

PGOR System Wind Curtailment + Constraint Results

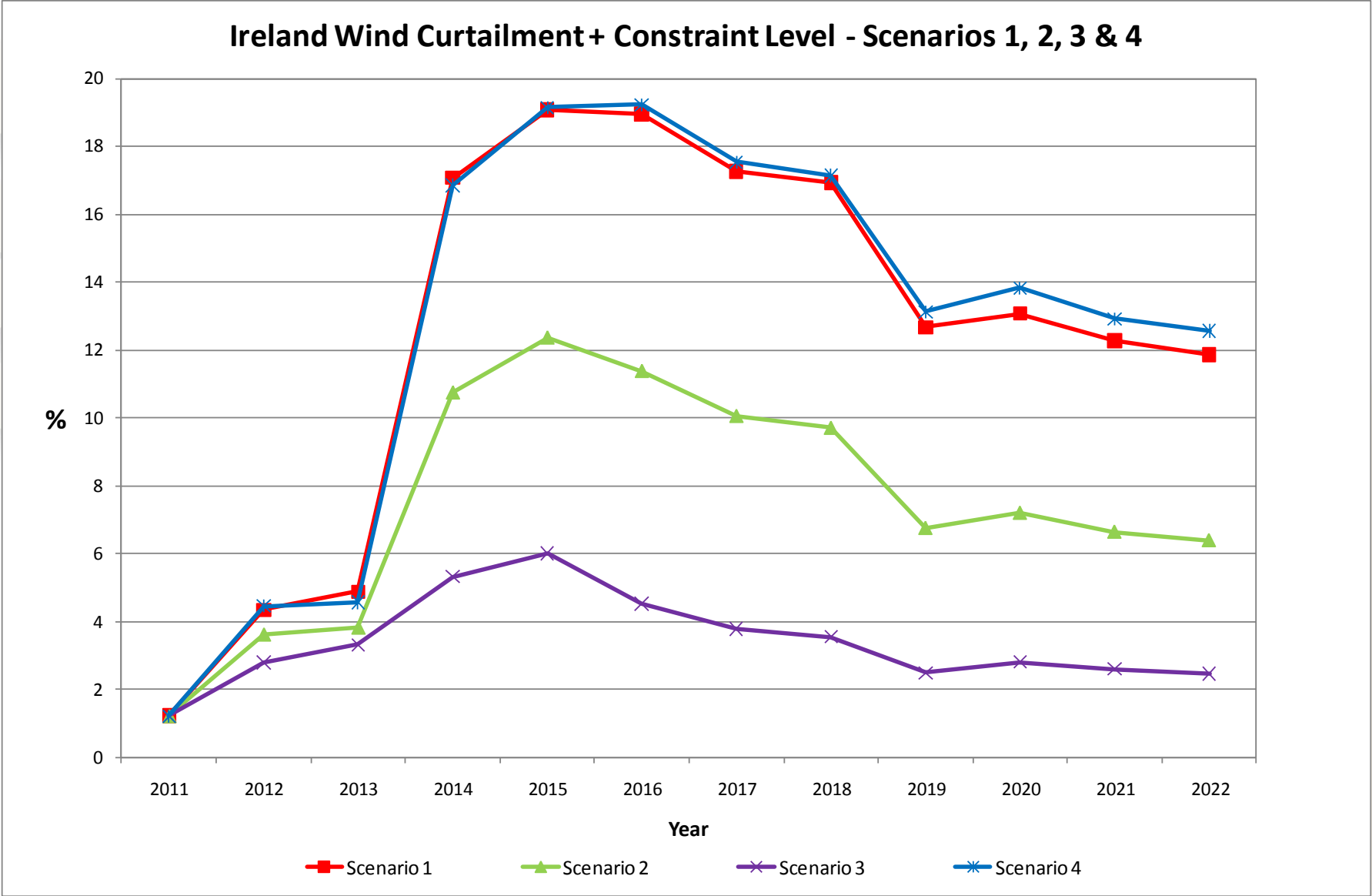

Indicative IE 2020 RES-E Energy

Indicative IE 2020 RES-E Energy	2020 SN1 (100% Gate 3 Wind)	2020 SN2 (66% Gate 3 Wind)	2020 SN3 (33% Gate 3 Wind)	2020 SN4 (100% Gate 3 Wind)
Installed Wind Capacity (MW)	6,576	5,213	3,891	6,576
Available Wind Energy (GWh)	18,535	14,676	10,946	18,535
Max Possible Wind Penetration (%)	55%	44%	33%	55%
Max Possible RES-E Penetration (%)	60%	48%	37%	60%
Wind Curtailment & Constraint (%)	13%	7%	3%	14%
Resulting Wind Penetration (%)	48%	41%	32%	48%
Resulting RES-E Penetration (%)	53%	45%	36%	52%



Future Plans

- The PGOR report for a Gate 3 Area will be published when all offers in an area have been issued.
 - Area K and Area D PGOR reports have already issued.
 - Workshops on curtailment/constraint levels will be held to answer more detailed queries on Area results.
- If the final dispatch rules differ from the draft set employed => Re-run of constraints model is required.
- Potential additional scenarios to be studied have been discussed at the Gate 3 Liaison Group. Whether these can be done depends on:
 - Whether a re-run is required due to a change in dispatch rules
 - Resources
- Possible re-run of constraints model starting in Q3 2011.

Summary

- Overview of constraints modelling presented.
 - ‘Physical’ curtailment/constraints determined
- CER have decided that EirGrid can issue interim constraints information in the form of PGOR Reports.
- High-level system results have been presented.
- Future plans have been outlined.



EirGrid Customer Forum

Transmission Network Planning “Optimisation”

Louis Fisher

Manager Transmission Network
Planning



EirGrid's TSO Mandate

EirGrid's Exclusive Function:

- to operate and ensure the maintenance of and, if necessary, **develop a safe, secure, reliable, economical and efficient electricity transmission system**, and to explore and develop opportunities for interconnection of its system with other systems, in all cases with a view to **ensuring that all reasonable demands for electricity are met** and having **due regard for the environment**;
- In discharging its functions under these Regulations, the transmission system operator shall take into account the objective of **minimising the overall costs** of the generation, transmission, distribution and supply of electricity **to final customers**.

Statutory Instrument 445 (2000)



Balancing of Conflicting Objectives

Security & Reliability

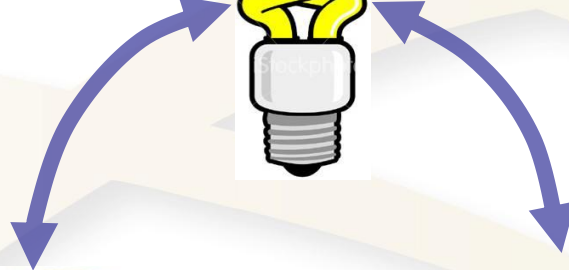

Costs & Efficiency



Community & Environment

Internal Project Approval Process

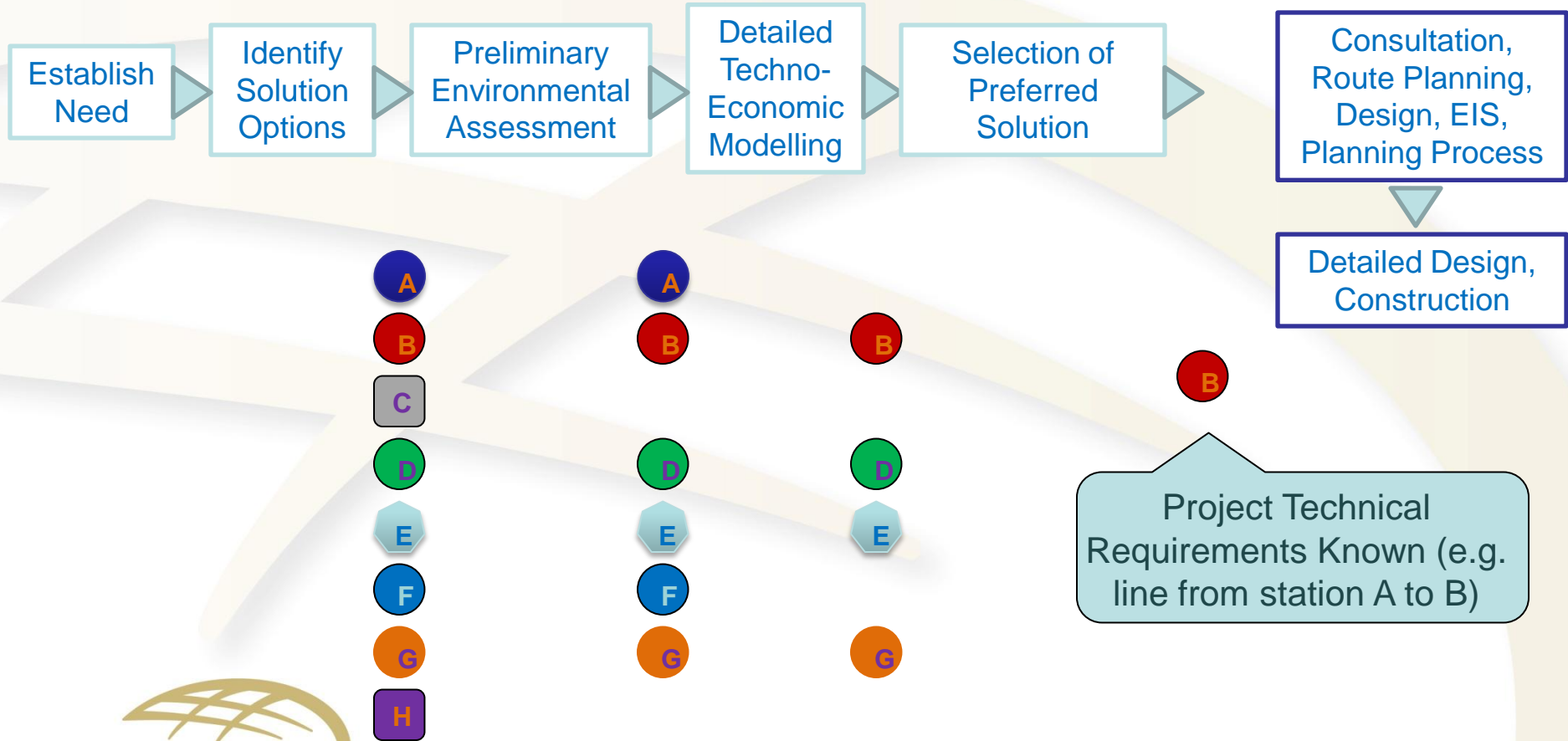

Assessment of Options

- Technical merit
 - Does the option resolve the technical problems identified (thermal loading, voltage, short circuit levels, stability)?
 - Does it comply with all aspects of the transmission planning criteria for a range of plausible scenarios?
- Economic analysis
 - For each option what savings result from reduced constraints and losses?
 - Do these savings exceed the initial capital and ongoing maintenance costs of the investment?

Assessment of Options

- Environmental Evaluation
 - Is there an available route for a circuit between stations?
 - Can a suitable site be found for a station in the study area?
- Flexibility
 - What are the likely future expansion requirements?
 - Can the plant be easily maintained and operated?
- Strategic
 - Can the option resolve multiple issues?
 - Does the option provide other benefits?
 - Security of supply



Meeting government's policies

Issues for Consideration

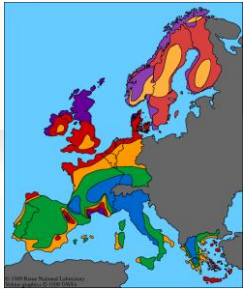

The National Spatial Strategy

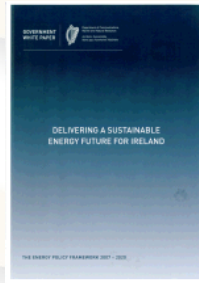
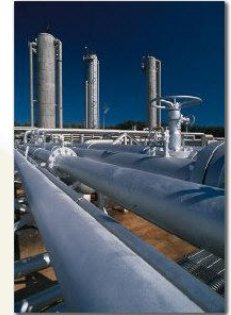

An Bord Pleanála

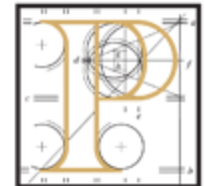

EIRGRID

CER

Commission for Energy Regulation
An Coimisiún um Rialáil Fuinnimh

Grid Development Strategy - Grid25



A Strategy for the
Development of Ireland's
Electricity Grid for
a Sustainable and
Competitive Future

GRID25

Expected level of Development:

- 2,200 km Upgrades
- 1,150 km New Build

ITC cases included reinforcement projects already under construction and planned, and development concepts identified in Grid25

Identified Development Requirements

 Demand

 Generation

 Interconnection



**Map of Transmission System
Indicating Areas Requiring Development
As at December 2009**

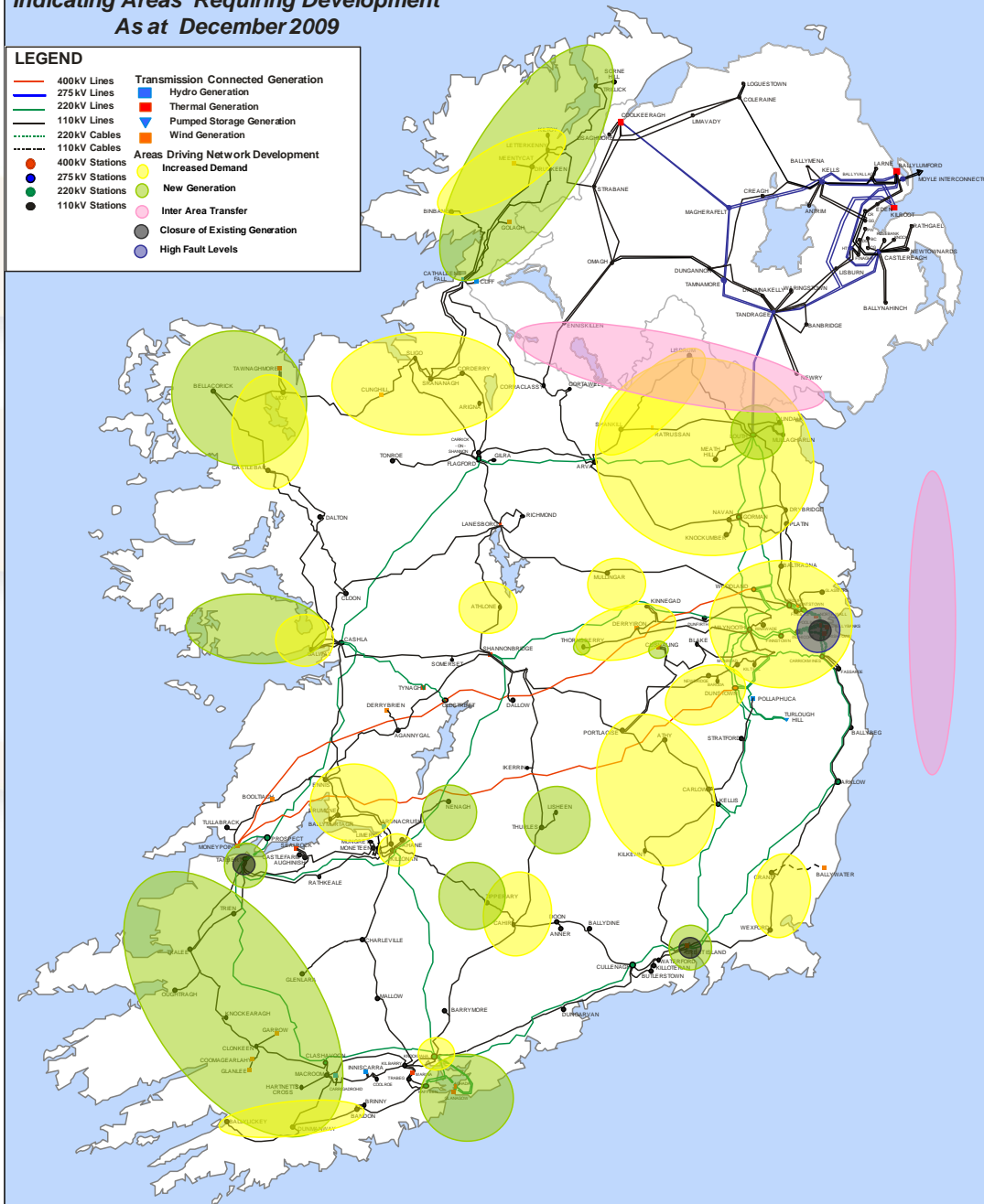
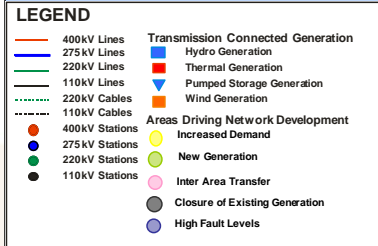

Transmission Projects in Progress

	400 kV / 220 kV/ 110 kV
No. of New Stations	16
Overhead Line	610 km
Underground Cable	33.1 km
No. of New Transformers	17
No. of New Capacitor Banks	12
Upgrades	665 km

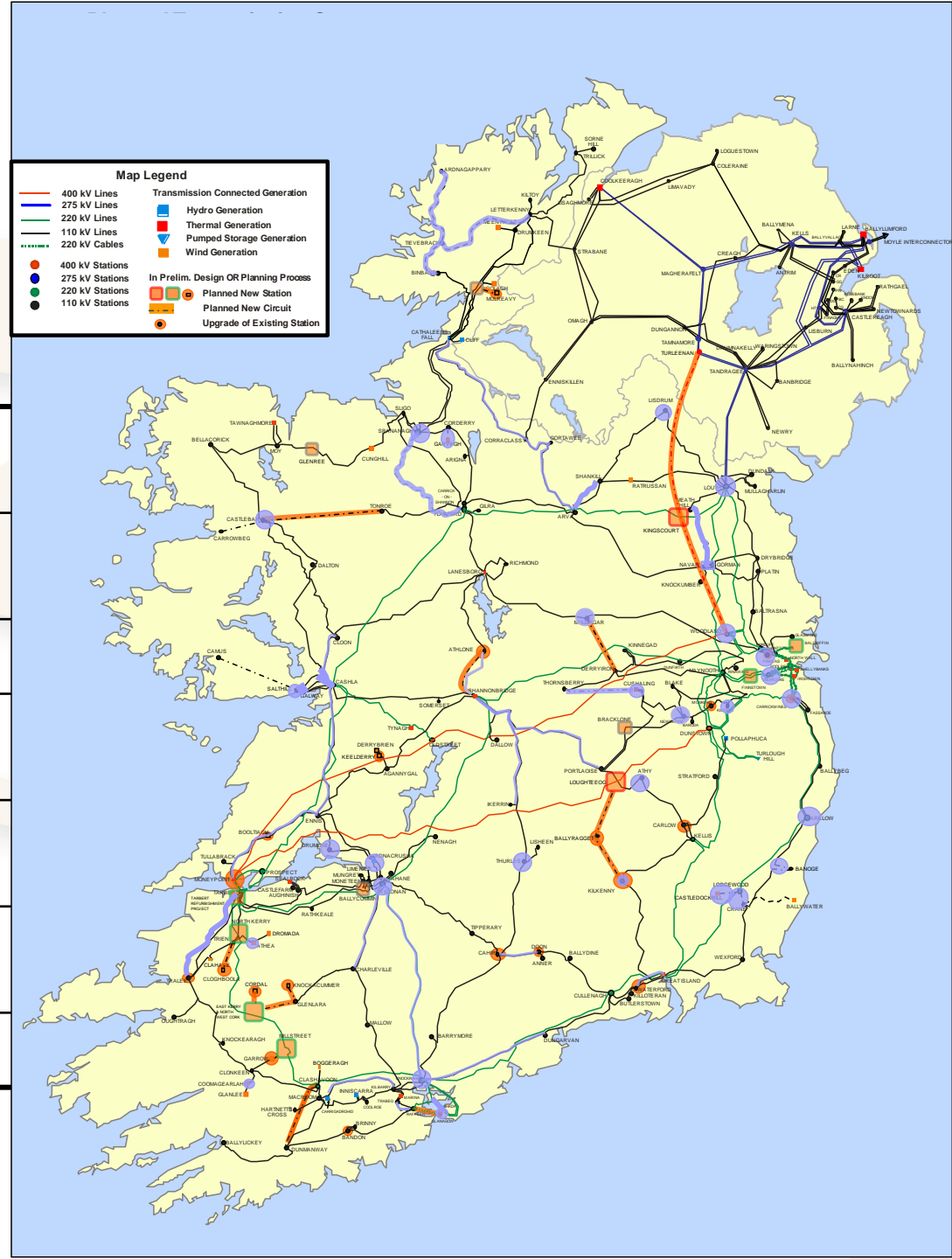
Main Areas in the Optimisation Process

- Technical Analyses Completed
- Evaluation of Economics and Environmental Considerations starting or in Progress

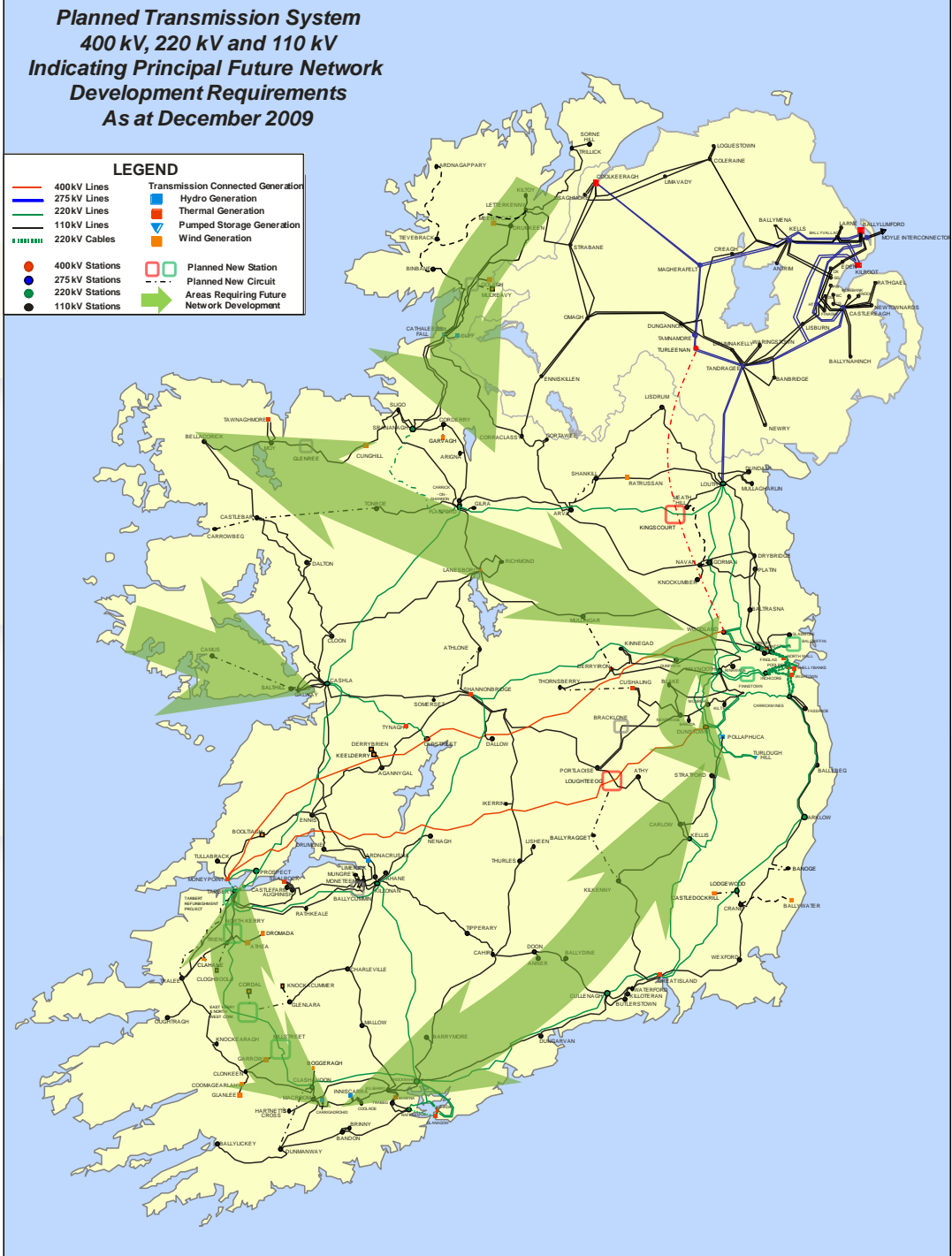

GOVERNMENT & EUROPEAN POLICIES / ECONOMIC INFLUENCES

TRANSMISSION DEVELOPMENT STRATEGY (GRID25)

Proposed
Network
Models
(2010-25)

ITC
Program

Deep
Reinforcement
Studies

Constraints
Studies

Network
Planning
Optimisation

Network
Build
Programme

Scheduled
FAQs

Associated Deep
Reinforcements

Forecast
Constraints

Transmission
Development
Plan

Summary

- Grid25 ITC network still meets needs
- Optimisation to ensure best and strategic solutions are selected
- Details of projects will emerge from transmission planning process
- As projects progress through planning to construction, robustness and justification will be re-checked
- Some change in details is inevitable

A possible future roadmap

Simon Grimes

Manager Transmission Access Planning

27 September 2010



Presentation Overview

- Factors influencing FAQs, deeps & constraints
- Proposal for future FAQ, deeps & constraints analysis
- Temporary connections
- Challenge of progressing Gate 3 connections
- Annual short circuit study proposal



Factors influencing FAQs, constraint levels and associated deeps

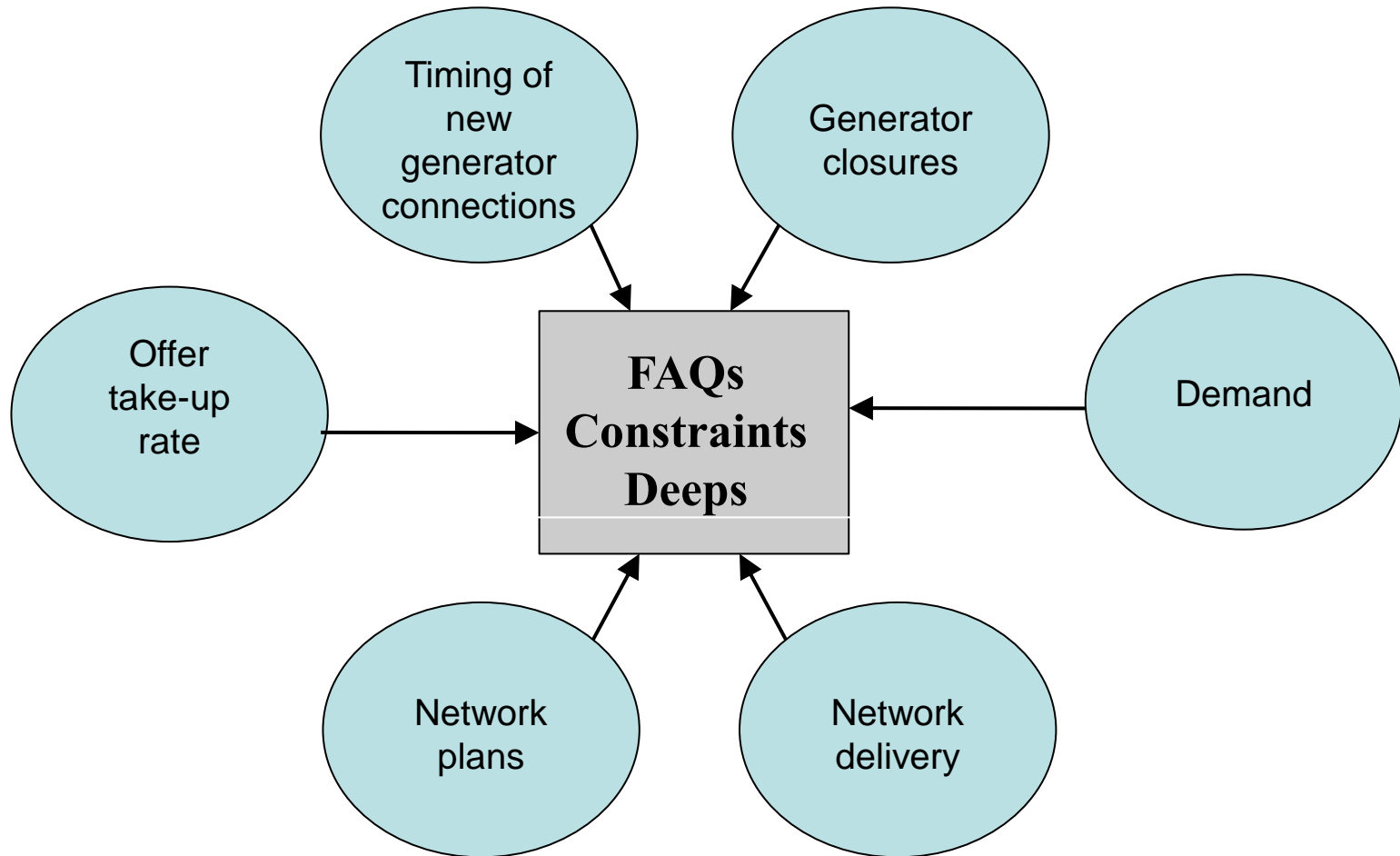

Assumptions which have changed since original ITC run

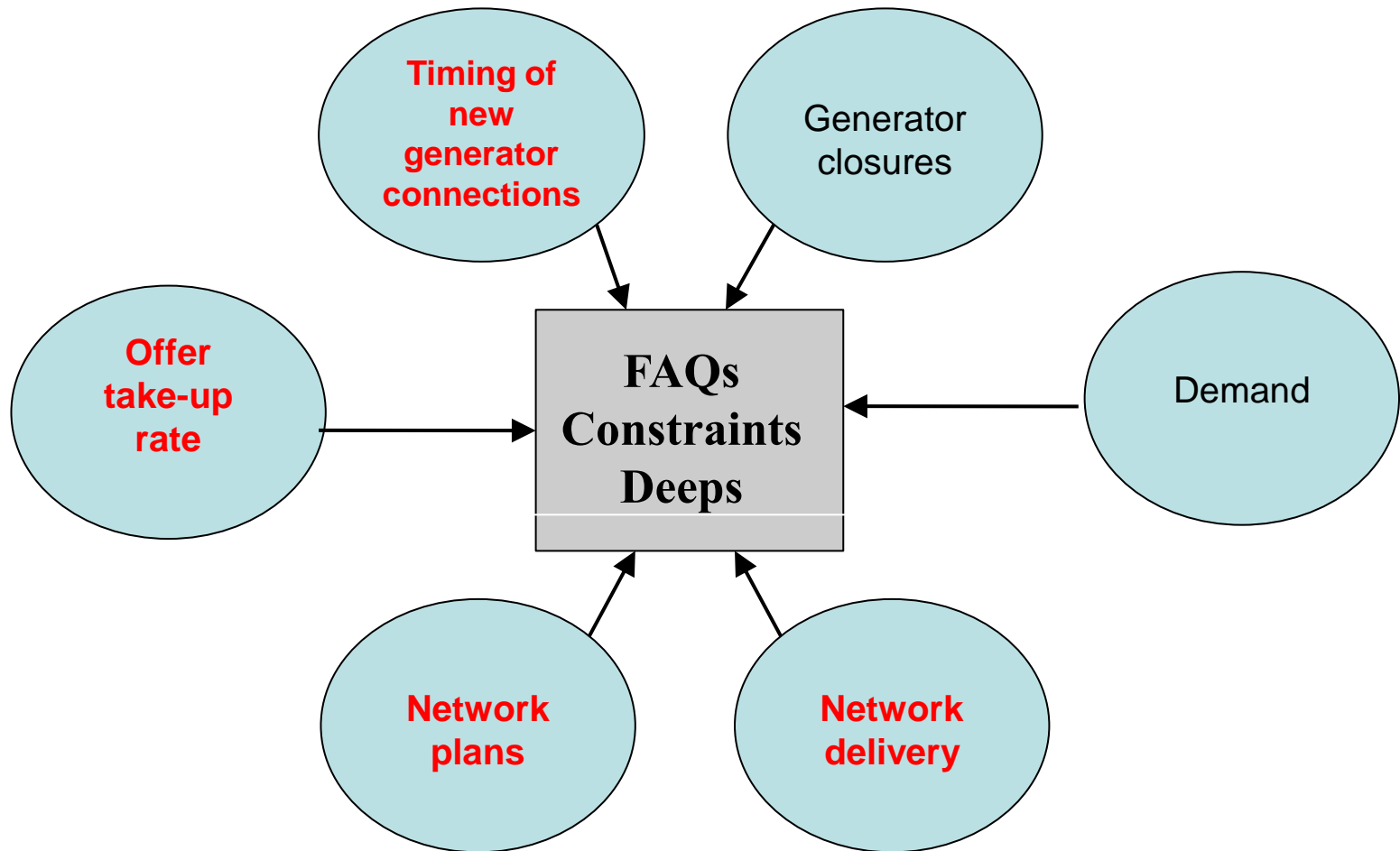

Proposal to deal with changing circumstances

- Annual analysis of FAQ, constraints & deeps
- To commence Qtr. 3 2011
- Results expected Qtr. 2 2012
- Considering how to deal with pre Gate 3 projects



Temporary Connections in Gate 3

- Capacity available?
- Who gets access where capacity available < capacity sought?
- CER rule-set tentatively expected Q1 2011



Gate 3 offer acceptances challenge

- Scale of concurrent application acceptances
- Challenge of progressing connections simultaneously
- ‘Implementation Plan’ being developed
- Offer take-up sensitivity analysis for 110kV connections

Short Circuit Driven Deep Reinforcements

- Some connections require sizeable number of circuit breaker replacements
- Gate 3 modelling based on standard connection lead-times
- Propose to undertake annual study to reflect actual timelines
 - Aim to facilitate as many new connections as possible
- Accurate connection/construction timelines is key

Roadmap Summary

- Annual FAQ, constraints, deeps study proposal
- Study to determine capacity for temporary connections
- ‘Implementation Plan’ to progress Gate 3 connections
- Annual short-circuit study proposal



TEA/COFFEE BREAK





EIRGRID

EirGrid Customer Forum Workshop Summary

Derek Lawler

Commercial & Pricing Manager

27th September 2010



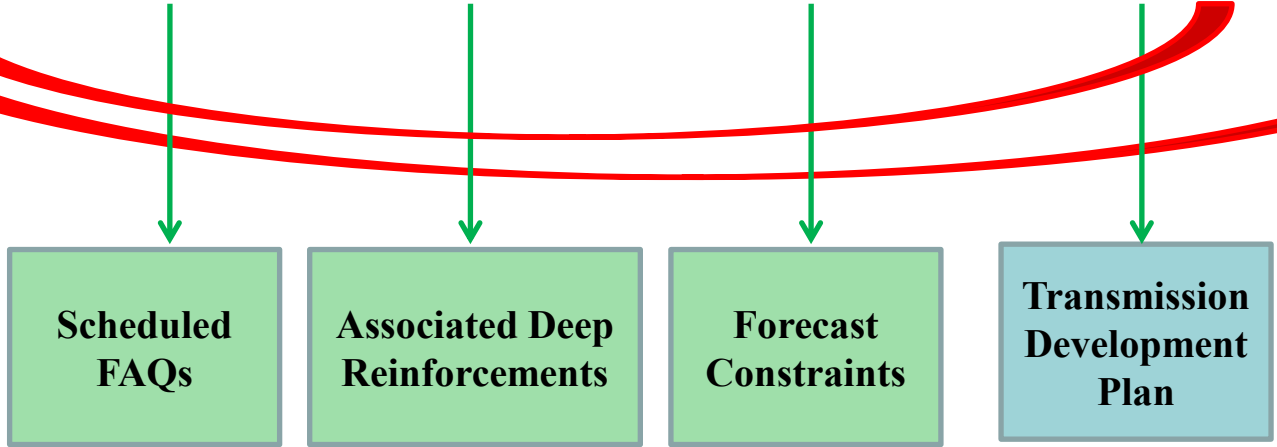

Key Messages

- Complex, dynamic process.
- Scale of work is unprecedented (Gate 3)
- Important updates proposed for all stakeholders:
 - FAQ's
 - Constraint Reports
 - Deep Reinforcements
- Support for industry to make informed decisions
- Feedback welcomed



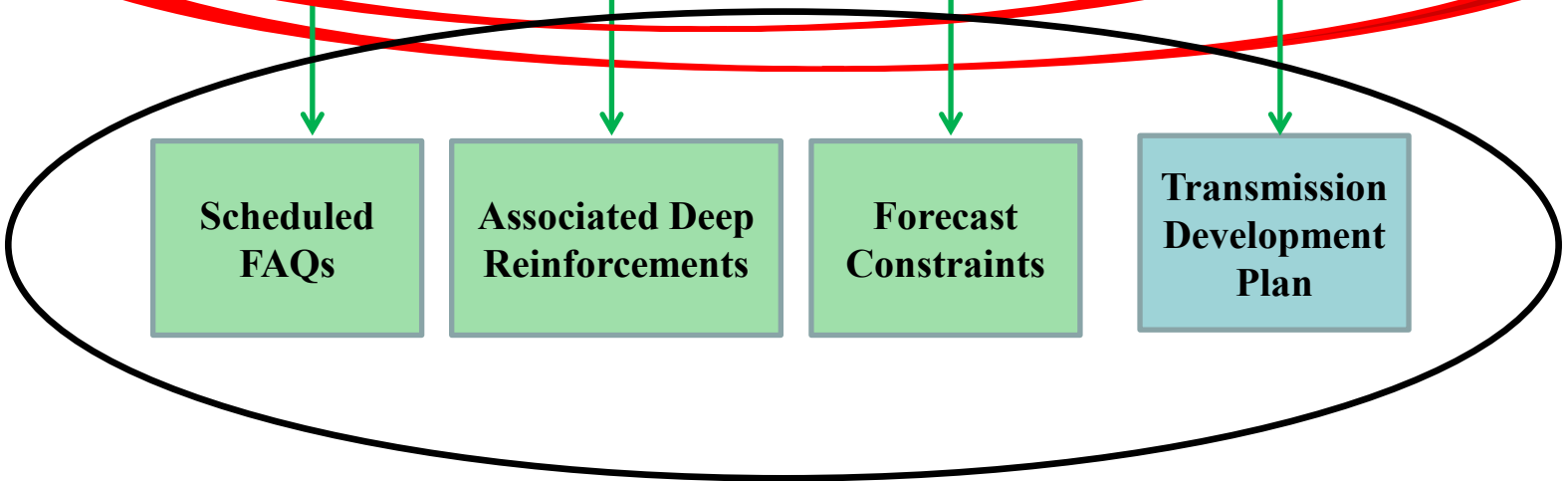
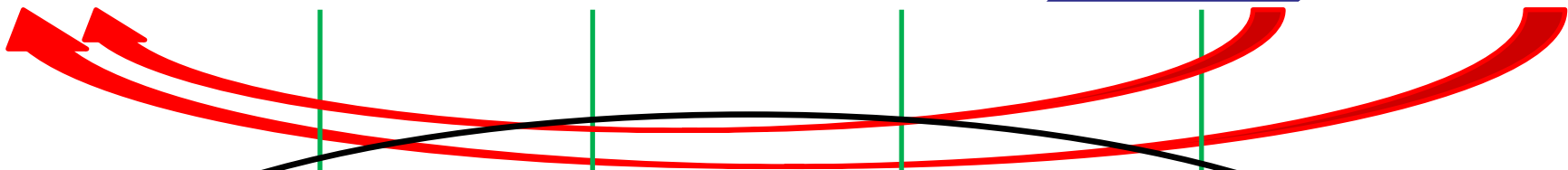

Key Messages

- Complex, dynamic process.
- Scale of work unprecedented (Gate 3)
- Important updates proposed for all stakeholders:
 - FAQ's
 - Constraint Reports
 - Deep Reinforcements
- Support for industry to make informed decisions
- Feedback welcomed



Next Steps

- Provide feedback to info@eirgrid.com
- Publication of Communications Plan/Process by end of November
- Additional workshop early 2011?



Thank you

